

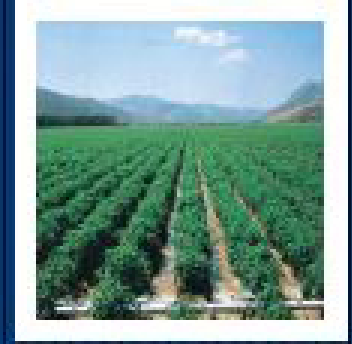

GAP ACTION PLAN

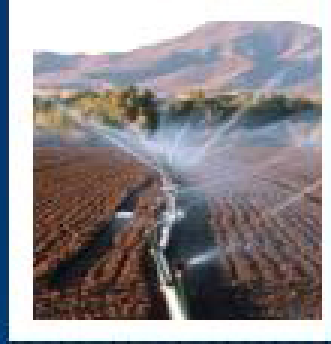
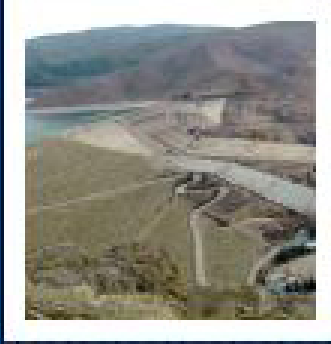

**“T.R. (TURKISH REPUBLIC) MINISTRY OF
DEVELOPMENT SOUTH-EASTERN ANATOLIA
PROJECT REGIONAL DEVELOPMENT ADMINISTRATION”**

**PLANNING IRRIGATION
AND IRRIGATION METHODS**



Uredjenje: *Olivera Stanić*

Urednik: *Prof. dr. sc. Miroslav Stanić*



PREPARED BY

Akif YENİKALE

(Agricultural Engineer, GAP-TEYAP Irrigation Expert)

Ayla YENİKALE

(Agricultural Engineer, MSc., GAP-TEYAP Irrigation Expert)



FOREWORD.....	6
INTRODUCTION.....	6
1.1. Definition and importance of irrigation.....	7
1.2. History of irrigation.....	8
1.3. Irrigation and irrigated farming in Turkey.....	9
2. LITERATURE SEARCH ON THE PREPARATION OF LAND FOR IRRIGATION...10	
3. IRRIGATION WATER NEED.....	11
3.1. Consumptive Water Use by Plants.....	11
3.2. Irrigation Efficiency.....	11
3.3. Effective Rainfall.....	12
3.4. Irrigation Water Need and Irrigation Interval on the Project Area.....	13
3.5. Irrigation Water Need for Each Irrigation and the Irrigation Interval.....	14
3.6. System Capacity.....	16
3.7. Planning the Irrigation Time.....	16
3.8. Factors Effecting Water Intake of the Plant.....	17
4. IRRIGATION SYSTEM AND METHODS.....	21
4.1. Choosing the appropriate irrigation method.....	22
4.1.1. Water Resource and the Characteristics of the Irrigation Water.....	22
4.1.2. Soil characteristics.....	27
4.1.3. Topographical Characteristics.....	27
4.1.4. Climatic Characteristics.....	28
4.1.5. Plant Characteristics.....	29
4.1.6. Economic conditions.....	29

4.1.7. Social and cultural situation.....	29
4.2. Flood irrigation method.....	29
4.3. Ponding irrigation methods.....	31
4.3.1. Border Irrigation Method.....	31
4.3.2. Graded Border Irrigation Method.....	36
4.4. Furrow Irrigation Method.....	38
4.5. Sprinkler Irrigation Method.....	46
4.5.1. Elements of Sprinkler Irrigation System.....	49
4.5.2. Types of Sprinkler Irrigation Systems.....	53
4.6. Drip Irrigation Method.....	57
4.6.1. Components of the Drip Irrigation System.....	58
4.6.2. Wetting Patterns and Lateral Arrangement Styles in Drip Irrigation Method.....	62
4.6.3. Advantages of the Drip Irrigation Method and the Factors Limiting Its Application.....	67
4.6.4. Amount of Irrigation Water Applied at Every Irrigation, Irrigation Interval and Irrigation Duration.....	67
4.6.5. Fertigation and the Problems Arising in Drip Irrigation Systems and Solutions Thereof.....	69
4.7. Under-Tree Micro Sprinkler Irrigation Method.....	74
4.8. In- Ground Irrigation Method.....	76
5. Project Examples	77
6. Bibliography	96

FOREWORD

With its suitable climate and fertile soil as well as an irrigation area of 1.8 million hectares targeted within the scope of the South-eastern Anatolia Project (GAP), the South-eastern Anatolia Region will no doubt be one of the most important agricultural lands in the world. Turkish farmers cannot obtain the expected yield, thus, the expected revenue, per unit area in the irrigation areas of the GAP region, 17% of which is currently being cultivated, due to problems arising from lack of knowledge on monoculture and irrigated farming. This may delay the expected contribution of GAP to the Turkish economy and the realisation of the targets of the investments made within this framework.

The GAP Agricultural Training and Extension Project (GAP TEYAP), implemented by the GAP Regional Development Authority within this scope, targets to develop a sustainable model which aims effective training and extension that will ensure optimum use of agricultural natural resources in the agricultural sector, which is a significant component in the achievement of regional development. In order for such a model to be successful, all activities related to “Irrigation and Effective Water Utilisation” have to be effective.

The success expected of irrigation depends on good knowledge and correct application of the subject. It is imperative that water be used efficiently and with a high application yield. Today, the irrigation systems that have the highest water application yield are the drip irrigation and sprinkler irrigation methods. The number of agricultural engineers with bachelor's or master's degree concerning the planning of irrigation systems and scheduling the irrigation times (SIT) is not adequate in the GAP region, as across Turkey. Hence, within the scope of GAP TEYAP, training activities covering theoretical and applied field demonstrations were carried out for the employees of public institutions, NGOs and the private sector in the GAP Region at 6 stages (Basic Irrigation, Irrigation Methods, Project Design and SIT, Demonstrations, Working Groups, Publications). A “GAP Irrigation Working Group” was established in the GAP Region. Carrying out effective extension and technical irrigation training, strengthened by demonstrations, for enhancing the agricultural training and extension activities in agricultural lands opened or to be opened to irrigation in the GAP Region and for increasing the capacities of institutions and establishments, especially farmers and farmers’ associations providing service on this subject will ensure a sustainable contribution.

It is aimed to provide technical and applied support in the transition process of the agricultural establishments of the GAP Region to modern irrigation, to increase the income levels by getting high quality and productive yield, and thus, to contribute to development in Turkey by improving the socio-economic and physical conditions of the Region. The target of the Agricultural Irrigation Strategy of the GAP TEYAP project is to ensure effective and sustainable use of the land and water resources of the GAP Region with transition to modern farming.

In this training text, prepared in line with these objectives and targets, the basic principles of “Irrigation Engineering” have been taken into account. All agricultural engineers can benefit the text with respect to content.

I hope that this book will be helpful to all those concerned and would like to thank everyone who contributed to its preparation.

Cevdet Yılmaz
Minister of Development

CHAPTER 1: INTRODUCTION

1.1. DEFINITION AND IMPORTANCE OF IRRIGATION

Plants receive water continuously from the soil through their roots to maintain their normal development, except winter period for perennials. This water taken by plants;

1. remains as water in the plant tissue,
2. is used to make a variety of compounds by breaking down in the plant,
3. is excreted through transpiration in plant leaves.

In terms of irrigation, the amount of transpiration from plant leaves are taken into account in calculation of irrigation water requirement of plants.

The existence of sufficient amount of moisture in the root zone of plants throughout the growing season is very important for plant growth. Too little or too much soil moisture content usually leads to a decrease in yield. This is illustrated by water-yield relationship curve.

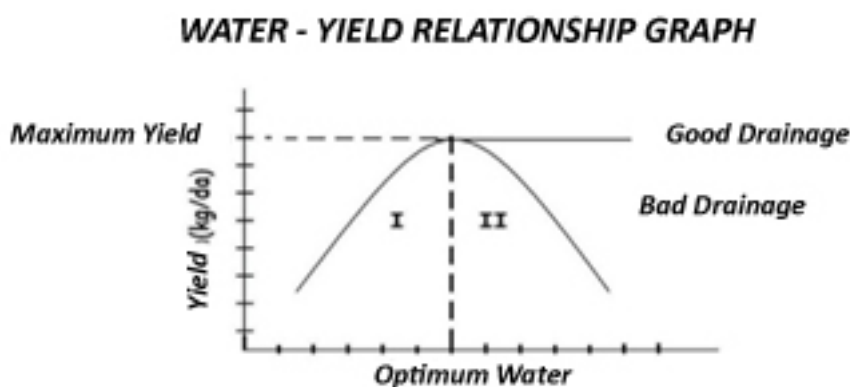

Figure 1.1 Water-yield relationship curve in plants

Provided that other agricultural inputs are fully met as shown in Figure 1.1, when the amount of moisture stored in the root zone of the plant during the growing season is increased, the yield increases and at a certain level of soil moisture, yield reaches its highest value. Even if the moisture content of the soil further increases under well drainage conditions, the yield remains constant, but under poor drainage conditions the yield again decreases as the water in plant root is more than necessary.

The reason for decrease of yield when there is too little moisture in the root zone during the growing season is the increase of retention of water molecules by soil particles as well as the fact that the plant has to apply more pressure through its roots to get water. This means that the plant will spend its energy for taking water from the soil instead of making products. The reasons for the decrease in yield under excessive moisture conditions due to poor drainage are the reduction of air and thus, the reduction of oxygen in voids of the soil, which results in:

1. the deceleration of the propagation of stem cells and the failure to provide the desired level of root growth,
2. the slowdown in activity of soil microorganisms which break down and convert the organic material into the nutrients which the plants can take,
3. the formation of harmful compounds in the soil, preventing the collection of plant nutrients.

Irrigation is giving to the plant root zone the amount of water that cannot be met by natural precipitation.

Irrigation is an agricultural input and when other agricultural inputs are not adequately suitable for the technique, vegetative production cannot be realised at the desired level only by irrigation. However, irrigation is an integral part of modern agriculture in terms of meeting the required level of water requirements of plants and increasing the efficiency of some other agricultural inputs.

General Benefits of Irrigation

- Prevents damage to the plant during short-term arid periods,
- Increases the yield per unit area and raises the quality,
- Allows the cultivation of various plants and getting more than one product a year,
- Prevents large fluctuations in production and income,
- Helps more efficient use of labour force,
- Chemical and microbiological functions of the soil useful in terms of plant nutrition increases,
- In the soil, toxic substances and salts which are harmful for plant development can be removed through washing by irrigation,
- In some cases, the soil and air temperature can be controlled by irrigation and frost can be protected through some irrigation methods
- After harvest, irrigation is used to bring the soil to processing temper and to provide the necessary moisture content for seed germination
- In some irrigation methods fertilizers and pesticides may be supplied in irrigation water,
- Environmental conditions are rendered more suitable for the growth of plants by refreshing the soil and the air surrounding the plant,
- Wind erosion resistance of the soil is increased by moistening it irrigation,
- The existing bedrock in the soil is softened.

1.2. HISTORY OF IRRIGATION

The history of irrigation starts with the history of mankind. It is known that primitive irrigation techniques have been used even before the birth of civilisations for vegetative production. Most of the civilisations have prospered in regions where there is water and irrigation is practised.

In general, Egypt is considered to be the first country where irrigation was practised well before B.C. Around 5000 B.C., the waters of the River Nile were diverted to agricultural lands. Around 3000 B.C., King Menes had the first known rock fill dam of the world built on the River Nile. Around 2000 B.C., the Egyptian Queen Semiramis had great irrigation canals constructed; some of these canals are still being used today.

Around 5000 B.C., in the Mohenjo Daro civilisation city in the Indus Valley in India, irrigation and drainage systems that are rather advanced compared to its time were built. In the Arab Peninsula, Turkey, Iran and other regions of the Middle East, irrigation practices were being carried out about 3000 years ago. Babylonian King Hammurabi had the state establish and operate the irrigation systems, subject to the codes he effected, and even punished the farmers who did not comply with these codes when using water.

TURFAN Karez Systems – This is historical agriculture artefact made by ancient people. A similar model of it is the Sheba (Sheba Kingdom) ancient dam irrigation systems built in Yemen and Ethiopia in the same years. The Karez irrigation system in China is longer than 5,000 km (3,106 miles) and is referred to as “the underground Great Wall”.

Despite rapid progress in many fields for centuries, especially the surface irrigation practises are similar to the ancient ones. The surface irrigation practises implemented in many parts of the world currently show little differences from the old irrigation systems. Typical examples of this is the dam built by King Menes, and high capacity canals and underground galleries extending many kilometres in Egypt and other countries.

1.3. IRRIGATION AND IRRIGATED FARMING IN TURKEY

During the Ottoman Empire, irrigation by the State started at the end of the 19th century. To this end, studies such as stream rehabilitation in Shkodra and Thessaloniki, construction of irrigation canals in Medina, instalment of an irrigation network on the Mosul plain were carried out. Among such studies, irrigation of the Konya Plain, which is inside the borders of Turkey today, occupies an important place. After the World War II, big irrigation projects were launched upon the establishment of the General Directorate of State Hydraulic Works (DSI) and currently projects that may be an example to the world are being carried out (for example, GAP irrigation).

There are 28.1 million hectares of agricultural land in Turkey. Of this area, it is maintained that 13.5 million hectares having a slope up to 6% are irrigable. In Turkey, the total water resources potential that can be used for consumption is 107 billion.m³/year, 95 billion.m³/year of this being surface water and 12 billion.m³/year being underground water. Unless the irrigation technologies applied in Turkey today are improved, the area that can be irrigated with the existing water resources is calculated to be 8.5 million hectares.

Turkey has a total area of 78 million hectares, and agricultural lands make up about one-third, i.e. 28 million hectares of this. According to the studies made, in Turkey, economically irrigable land is 8.5 million hectares, and as of 2004, a total of 4.9 million hectares was being irrigated. Of this total irrigated area, 2.8 million hectares have modern irrigation network constructed by the State Hydraulic Works (DSI). 1.1 million hectares have been put into operation by the former General Directorate of Rural Services (KHGM). In addition, public irrigation is practised on 1 million hectares. It is targeted to put into operation by the General Directorate of State Hydraulic Works 6.5 million hectares of the economically irrigable 8.5 million hectares by 2030, and it is expected that the remaining 1.5 million hectares will be put into operation by other public institutions and that the remaining 0.5 million hectares will be irrigated within the scope of public irrigation.

According to the General Directorate of State Hydraulic Works, about 1/3rd of the economically irrigable 8.5 million hectares is being irrigated. This area, which is 2.8 million hectares, makes about 10% of the total agricultural land in Turkey (28 million hectares). As of early 2005, the 2.8 million hectares making 57% of the 4.9 million hectares total irrigated area in Turkey is being irrigated by the DSI; and by 2030, the area being irrigated by the DSI will be 6.5 million hectares and the ratio will be 76%.



In Turkey, where about 58% of the 8.5 million hectares of economically irrigable agricultural land is irrigated, irrigation of the remaining approximately 3,61 million hectares of land and construction of irrigation facilities required for this immediately bears special significance to meet the nutritional needs, to produce the agricultural products which are the needs of industry in a balanced manner and continuously, to solve the unemployment problem of the working population in the agricultural sector and to rise their level of life.

In approximately 94% of the total area, surface irrigation methods (furrow, border and flood) are used. In the remaining part pressurized irrigation (sprinkler and drip) is used. Traditional (transportation of pipes by hand) sprinkler irrigation is common among farmers across the whole country and it is estimated that 200,000 hectares are irrigated by this method. Area of more than 80,000 hectares are irrigated by sprinkler irrigation in DSI irrigations. There is the obligation to improve the existing irrigation technology for optimal use of our resources.

2. LITERATURE SEARCH ON THE PREPARATION OF LAND FOR IRRIGATION

When providing irrigation service for a specific agricultural area, one need to gather information at first to prepare the land for irrigation, plan the irrigation systems, size and operate the system elements. The required information for this is described below:

- **Planning Map:** The topographical map of the land to be irrigated
- **Agricultural Structure and Ownership Status:** Cadastral map
- **Soil Characteristics:** Acquisition of data such as soil's textural class, structure, effective depth of soil, usable water holding capacity, salinity, sodicity, permeability, infiltration characteristics.
- **Plant Characteristics:** Information related to vegetation pattern and cultivation ratio, irrigation module, depth of soil to be irrigated, soil humidity prior to irrigation, amount of irrigation water for each irrigation, irrigation duration and interval, preparation of soil, plant protection and harvest.

- **Water Resource Characteristics:** Identification of the type, location, height, water intake structure, quality class and flow rate (max & min) properties.
- **Climate Information:** Long term average (for example the last 10 years) of data such as latitude & longitude, height, first & last frosts, monthly average temperatures, precipitation, relative humidity, wind velocity and direction, sunshine duration and atmospheric pressure should be taken. The meteorological station closest to the irrigation project area should be used to obtain these data.
- **Other Data Depending on Need:** Information related especially to the supply of materials and technical labour force, special conditions of the farmer -if there are any-, and natural energy and automation information for sustainable irrigation technologies may be used.

3. IRRIGATION WATER NEED

In order to determine the irrigation water need of plants, one needs to know the amount of water used by the plant, the percentage of this amount provided by rainfall (effective rainfall) and the irrigation efficiency which includes the losses that occur during the conveyance and distribution of the irrigation water.

For the calculation of the irrigation water need, it is required to explain concepts such as consumptive water use by plant, effective rainfall, irrigation efficiency and planning of the time of irrigation.

3.1. Consumptive Water Use by Plants

Consumptive water use by plants (evapotranspiration) is the sum of the amount of evaporation from the soil surface and the amount of transpiration from the leaves of plants. Usually, it is defined in terms of depth (mm). The factors effecting evapotranspiration is given in Figure 1.1. Evapotranspiration is measured directly or in application or estimated using climate data. Although direct measurement methods give more reliable results, they are very expensive and time-consuming. Thus, direct measurement of consumptive water use by plant is carried out only for the purpose of calibrating the estimate equations of climate data and calculating endemic plant coefficients. Consequently, in practice, evapotranspiration values are determined mostly using the estimate equations which are based on climate data.

Many equations that can be employed in the estimation of consumptive water use by plants using climate data have been developed. These are:

- 1 - Penman – Monteith Method
- 2 - Pan Evaporation Method
- 3 - Blaney – Criddle Method

3.2. Irrigation Efficiency

Efficiency, in general, represents the rate of utilization of an available potential. Since the utilized resource in irrigation practices is water, the irrigation efficiency defines how utile the water obtained from the water resource is after being given to the land. Only a certain percentage of the water transported to the land is taken by the plant. The rest can be divided into two as the losses that occur in the water conveyance and distribution canals and the losses that occur in the field.

The losses that occur in the water conveyance and distribution canals are caused by seepage and evaporation. Evaporation losses are little when compared to seepage losses so they can be ignored. The water loss in the field involves percolation of water below the plant root zone and movement of water from the field with surface runoff. Cost of water, capacity of the water resource, climate conditions, available labour force, water control and soil and plant characteristics also influence the irrigation efficiency. The water obtained from the water resource goes through several stages until it is used by the plant. A separate efficiency exists for each stage. These efficiencies, each being a component of the total irrigation efficiency, are given below:

- Transpiration efficiency
- Water conveyance efficiency
- Water application efficiency

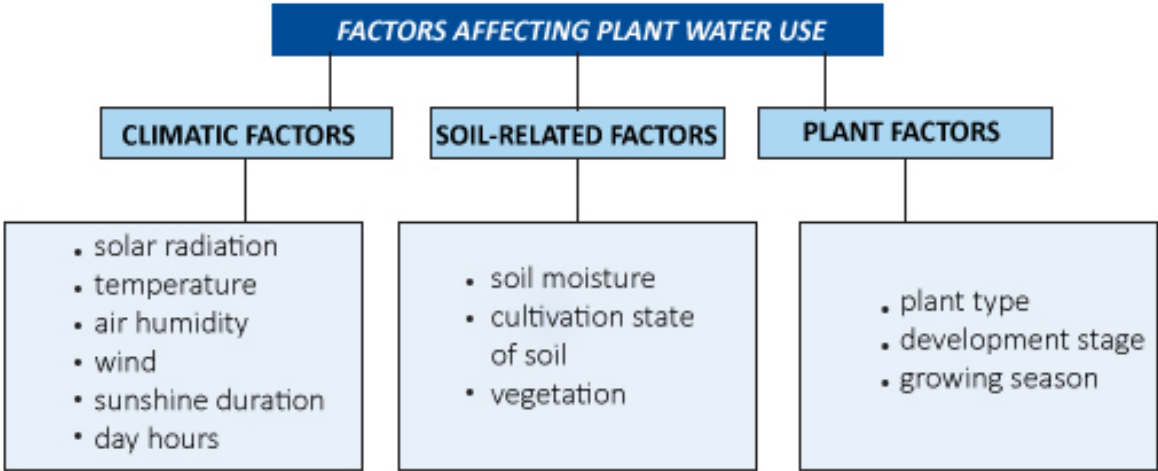

Figure 1.1. Factors affecting evapotranspiration

3.3. Effective Rainfall

Some part of the water that plants need during their growing season is met by rainfall as stated above. However, plants cannot use all the rain water because some of it is carried away with runoff and some percolates below the plant root zone. The amount of rain water that is stored in the root zone in soil and used by the plant is called the effective rainfall. It is important to know the effective rainfall amount for the calculation of the percentage of consumptive water use by plant to be provided by irrigation. If the measured rainfall is below 25 mm, this value can directly be taken as the effective rainfall. When the measured rainfall is greater than 25 mm, the ground rainfall values can be obtained from Figure 3.1. The values in the table give the ground rainfall as percentage of the ground rainfall.

Measured rainfall (mm)	Net irrigation water (mm)	consumptive water use by plant (mm /day)						
		2	3	4	5	6	8	10
25	10	42	44	46	49	52	60	62
	20	49	52	54	58	62	71	73
	30	54	57	60	64	68	79	81
	50	63	66	69	74	79	91	93
	100	68	72	75	81	86	99	100
	150	71	75	78	84	90	100	100
50	10	41	44	45	48	51	60	62
	20	48	51	53	57	60	71	73
	30	53	57	59	63	66	79	81
	50	61	65	68	73	76	91	93
	100	67	72	74	80	84	99	100
	150	70	74	77	83	87	100	100
75	10	40	42	44	48	50	59	62
	20	47	50	52	56	59	69	73
	30	52	55	58	62	65	77	81
	50	60	63	67	72	75	88	93
	100	65	69	73	79	83	97	100
	150	68	72	76	82	86	100	100
100	10	40	41	44	46	49	57	62
	20	46	48	52	54	58	67	73
	30	51	54	57	60	64	75	81
	50	59	62	66	69	74	86	93
	100	64	68	72	75	81	94	100
	150	67	70	75	78	84	98	100

Figure 3.1. The ratio of effective rainfall to ground rainfall (%)

3.4. Irrigation Water Need and Irrigation Interval on the Project Area

In general in irrigation projects, a high number of plants are cultivated on the project area. Thus, firstly, average values for consumptive water use by plants are calculated on a monthly basis. To this end, monthly evapotranspiration values for each plant are derived and weighted averages of evapotranspiration values of a certain month are calculated depending on planting ratio. The average net and total irrigation water needs of the project area are:

$$dn = ET_{ort} - r$$

$$dt = dn / E$$

where

- dn = Net irrigation water need of the project area, mm/month
- ET_{ort} = Average consumptive water use by plant on the project area, mm/month
- R = Effective rainfall, mm/month
- dt = Total irrigation water need of the project area, mm/month, and
- E = Total irrigation efficiency of the project area, %

Net irrigation water need is the amount of consumptive water use by plant met by irrigation water and means the amount of water that has to be stored in the root zone of the plant. The total irrigation water need is derived by correcting the net irrigation water need by irrigation efficiency. The irrigation module used in expressing the irrigation water need per unit area is

$$q = \frac{10dt}{3,6T}$$

where

q = Irrigation module, L/s/ha

dt = Total irrigation water need on the project area, mm/month

T = Duration of irrigation, h.

The irrigation module for a certain project area is calculated separately for every month. The amount of irrigation water to be given to the project area for a certain month is derived from these values. Also, at the planning stage, the canal capacities are determined according to the maximum irrigation module value. The value T in the equation is calculated by multiplying the number of days in the month by the duration of irrigation per day.

3.5. Irrigation Water Need for Each Irrigation and the Irrigation Interval

The net amount of irrigation water to be applied at each irrigation is calculated as follows: when the usable water holding capacity is given in %

$$dn = \frac{(TK - SN) Ry}{100} ytD$$

when the usable water holding capacity is given as depth

$$dn = dkDRy$$

where

dn = Amount of net irrigation water to be applied at each irrigation, mm

TK = Capacity of the field, %

SN = Wilting point, %

Ry = The part of the usable water holding capacity that is allowed to be consumed,

Yt = Weight per volume of the soil, g/cm³,

D = Soil depth to be wetted, mm

dk = Usable water holding capacity, mm/m

In these equations, the net amount of irrigation water to be applied in each irrigation expresses the amount of irrigation water desired to be stored in the root zone of the plant. The depth of

the soil to be wetted is generally taken as the effective root depth of the plant. However, in shallow soils where the depth of effective soil is less than the effective root depth, effective soil depth should be taken as the soil depth to be wetted.

In irrigation applications, soil moisture at the effective root depth is not expected to fall to the wilting point. Irrigation is started at the upper soil moisture level. This is expressed as the R_y value which is the part of the usable water holding capacity that is allowed to be consumed by the plant.

The R_y values here vary depending on the irrigation methods and the sensitivity of the plant to moisture deficiency in the soil. This value is generally assumed to be higher in surface irrigation methods and for plants that are not sensitive to moisture deficiency in the soil. In the irrigation of cultivated plants, the R_y values are assumed to be 0.50-0.60 for surface irrigation methods, 0.50 for sprinkler irrigation method, and 0.30-0.40 for drip irrigation method and under-tree micro sprinkler irrigation method where small sprinkler heads are used.

The total amount of irrigation water to be applied on the fields at each irrigation application is calculated by correcting the amount of net irrigation water with water application efficiency.

$$dt = \frac{dn}{Ea}$$

where

dt = Amount of total irrigation water to be applied at each irrigation, mm

dn = Net amount of irrigation water to be applied at each irrigation, mm

Ea = Water application efficiency, %

In the above equation, the water application efficiency is the ratio of the amount of water stored in the root zone of the plant to the amount of water applied to the field. This value may vary between 0.30-0.80 in surface irrigation methods, 0.65-0.80 in sprinkler irrigation method, and 0.85-0.95 in drip irrigation method. The values given in this equation express the total amount of irrigation water needed per field. The amount of total irrigation water needed at the water resource is:

$$dt = \frac{dn}{EaEc}$$

where

dt = Amount of irrigation water needed at the water resource, mm

dn = Amount of irrigation water desired to be stored in the root zone of the plant, mm

Ea = Water application efficiency, %

Ec = Water conveyance efficiency, %.

In field irrigation systems, the water conveyance efficiency is about 70% in earth canals, and about 85% in concrete covered canals. In systems where water is conveyed by pressurised pipe lines, this value may be taken as 100%.

Irrigation interval is calculated by dividing the net amount of irrigation water applied at each irrigation by the daily water consumption of the plant:

$$SA = \frac{dn}{ET}$$

where

SA = Irrigation interval, days

dn = Net amount of irrigation water to be applied at each irrigation, mm

ET = Water consumption of plant, mm/day.

Since usable water holding capacity is higher in heavy soils compared to light soils, the net amount of irrigation water to be applied at each irrigation will also be higher. Thus, the irrigation interval is also longer. In addition to this, as water consumption values change during the growing season, the irrigation interval will also change. Plants are irrigated at longer intervals during the initial growth period, and are irrigated at more frequent intervals during the periods when growth is at its highest level.

3.6. System Capacity

The capacity of a certain irrigation system is given by the following formula:

$$Q = \frac{Adt}{3.6T}$$

This equation may also be used in expressing the total irrigation water need found in mm (in the calculation of total amount of irrigation water to be applied at each irrigation and the total amount of irrigation water) in L/s, or to determine the amount of irrigation water available at the water resource and the duration of irrigation of a certain field plot.

In this equation:

Q = System capacity, L/s,

A = Area to be irrigated, decares,

dt = Total need of irrigation water, mm,

T = Duration of irrigation, h.

3.7. Planning the Irrigation Time

The purpose in planning the irrigation time is to determine the time to start irrigation and the amount of irrigation water to be applied. To carry out these processes information such as the characteristics of the plant being cultivated, the soil depth to be wetted, usable water holding capacity of the soil, moisture level to start irrigation, the net amount of irrigation water to be applied at each irrigation application and consumptive water use are required. The basic principle in planning the irrigation time is to apply irrigation water sufficient to raise the soil moisture up to the field capacity when the soil moisture decreases to the moisture level at which irrigation should be started.

Irrigation time may be planned with various methods. The mostly used methods are as follows:

Planning the irrigation time by phenological observations: In this method, the irrigation time is decided by observing the colour, vitality and angle of plant leaves. The method requires experience and gives rough results. Generally, it leads to low or excessive water use.

Planning the irrigation time by checking the soil moisture by hand: The soil specimens taken from the root zone of the plant are checked by hand to determine whether they have fallen to the moisture level at the start of irrigation. Irrigation water sufficient to raise the soil moisture at the

start of irrigation up to the field capacity is applied. This method also requires experience and gives rough results, leading to low or excessive water use.

Planning the irrigation time by measuring the soil moisture: The moisture level to start irrigation is determined by measuring with tensiometers or by the neutron method. The moisture level at the plant root zone to start irrigation should first be calculated.

Planning the irrigation time by consumptive water use: The basic principle of this method is to calculate the daily soil moisture changes at the root zone after preparing a water balance according to the water balance model. To this end, firstly, the field capacity at effective plant root depth and the moisture level to start irrigation must be expressed in terms of depth and the daily consumptive water use values must be calculated.

3.8. Factors Effecting Water Intake of the Plant

The factors effecting water intake of plants can be divided into two main groups, as factors related to the environment of the plants and the plant factors.

1. Environmental factors: Environmental factors have great impact on water intake of plants. Firstly, the soil must contain the amount of water that the plants can intake. When the plant roots start absorbing water at a point, the thick water ring under the capillary surface gets thinner and the surface concavity of the capillary tubes in the soil increases. This increases the capillary attraction and the capillary water starts moving toward the absorption point where there are capillary water roots. The direction and speed of this movement depend on the size of the difference between the tension gradients formed in the soil and the permeability of the capillary cavities.

The capillary roots of a plant automatically forms a tension gradient by absorbing the moisture of the soil and water flows toward the active root surface. However, as supply of water through capillarity is low, this may not always happen. Plants need a high amount of regular and rapid water flow in the soil. The water in the soil may reach the point where the roots are more rapidly and at the desired amount by moving through mass movement or by diffusion. However, plant roots do not always wait for the water in the soil to come to them, but they grow to move toward the direction where the water is. The plant movement toward the direction where the water is also called hydrotropism. This gains importance through the distribution pattern, amount and depth of the plant roots in the soil.

Plants may intake up to water retained at 15 atmospheres in the soil; they cannot use water retained at a higher pressure.

The amounts and types of the salts in the soil also effect water intake. Increase of the salt concentration in the soil causes the increase of the osmotic pressure. If a pressure higher than the osmotic pressure in the roots builds up, the roots cannot intake the water in the soil; they even may start to give away the water in them. However, at this point active water intake may take part and some plants may continue to intake water despite a certain level soil salinity (high pressure). Such plants are considered as partly resistant to drought and saltiness.

The temperature of the soil also has an effect on the capacity of plants to intake water. Consequently, soil temperature is desired to be between 8-25 °C on the average. Temperature decrease lowers water intake, especially for plants that like hot weather. For example, when the temperature decreases from 20 °C to 10 °C, water intake decreases by 20-30% for greenhouse tomatoes, while for cabbages, which are plants of cool climate, water intake increases by 30-40%. Cabbages decrease water intake only when soil temperature drops down below 5 °C. Consequently, every plant has an optimum water intake level at a specific temperature.

The factors that restrict water intake by plants at low temperature are as follows:

- a. Root growth is restricted and root activity is reduced.
- b. Membrane permeability of root cells decrease.
- c. The activity and permeability of cell protoplasm decrease.
- d. The viscosity of water increases.
- e. Vapour pressure of water decreases.
- f. Movement of water from the soil to the roots decreases.

Just like water intake decreases at lower temperatures, the same effect is also observed at very high temperatures.

Another factor having impact on water intake of plants is the air in the soil. As the amount of oxygen in the soil decreases and the amount of carbon dioxide increases, water intake slows down. The soil medium lacking air increases the viscosity in root cells and reduces water entrance to the root. Thus, plants cannot intake water. Heavy and long duration precipitation, rise of the water table, and unconsciously excessive and frequent irrigation cause the increase of water in the soil, filling all cavities in the soil with water, and as a consequence, lack of air in the soil. As is known, plants need a certain amount of air in the soil as well as water to continue their normal growth. As a result of the increase of the amount of water in the soil and in turn, the decrease of the amount of oxygen, the followings occur:

1. While the first condition for adequate development of organs above the soil in plants is a well developed root system, division and propagation of root cells slow down and the desired root development cannot be attained.
2. The activity of soil microorganisms, which decompose the organic matter in the soil and transform it into nutrients for the plant, slow down.
3. Hazardous compounds which inhibit intake of the plant nutrients in the soil are formed.

All these factors effect plant development, thus, a decrease in yield.

In summary, one of the important conditions to ensure normal development of a plant is to provide moisture at an adequate level in the soil. On the other hand, under good drainage conditions, the excess water in the soil penetrates under the plant root zone, with no other important problem than washing and removing from the constituents of plant nutrients from the root zone.

2. Plant Factors: Intake of the water in the soil by plants will naturally vary significantly by some characteristics of the plant. As the distribution pattern and structural features of a plant may vary under different environmental factors, their functions may also vary. The consumptive water use values will also change during the development period. This will change depending on plant genus and species as well as the environmental factors and cultivation treatments applied within the life cycle of the plant. Examples of such mentioned variations are the development duration of the plant, its anatomical structure, amount and depth of root development, water absorbance strength of the roots, the growth balance and relation between the organs under and above the ground, etc.

Among the factors mentioned above, especially root development of the plant has an influential and great role with respect to the plant-water relation. In addition, again with respect to the root, there are many side factors such as growth rate of the root, root depth, amount of absorbent root hairs, botanical structure and absorbing power of the root.

Many factors affect the water requirement of plants besides their genera and species and rainfall, such as method of irrigation, amount and number of irrigation water, temperature, relative humidity of air, wind speed and the status of the day and the season, etc.

Consumptive water use by plants is used synonymously with “evapotranspiration”. Evapotranspiration is the sum of the amount of evaporation from the soil surface and the amount of transpiration from the leaves of plants. Usually, it is defined in terms of depth (mm). In practice, it is difficult to separately measure evaporation and transpiration; in fact, this is not necessary in respect of irrigation. The important thing in irrigation is to assess the amount of reduction in soil moisture. Consequently, evaporation and transpiration are measured or estimated together in irrigation applications.

Consumptive water use by plants are determined for different time intervals: daily, monthly and seasonal. Each of these intervals are very effective on some decisions to be taken both in planning and operating irrigation systems. For example, the values for the month when consumptive water use is the highest are used in determining the capacity of the constituents of the irrigation system, especially the water conveyance lines; daily consumptive water use values are used in determining the time and intervals of the irrigations conducted within the season; and the seasonal consumptive water use values, which expresses the consumptive water between the start and end of the plant development period, are used in the calculation of irrigation water to be stored (taken) in ground or underground resources.

As can be understood from the above explanations, consumptive water use is influenced by four main factors: climate, soil, plant and irrigation application. As temperature increases and movement of air speeds up, plant transpiration increases proportionally. However, after a certain temperature and air movement speed, the plant stops transpiration to protect itself. To this end, it closes its stomata. The amount of water the plant loses effects its water intake significantly. In plant water loss, the anatomy of the leaves, the number of stomata and stomata movements also play an important role. Normally, light, temperature and intrinsic materials which effect the stomata movements indirectly effect water intake of the plant. As can be seen, determining the water requirement of the plant is a difficult and complicated issue, which can be revealed by examining direct and indirect, individual and mutual interactions of many factors.

Water, nutrients taken from the soil and the vegetation time play an important role in plant development. Taking the nutrients into the plant requires that the molecules and ionic parts of these nutrients are completely dissolved and released in water. This way, such matter can be taken into the plant to provide development.

Observing the plants to decide for irrigation time is a method used generally in practice. In this method, usually the withering of the leaves are considered. In plants, there are two types of withering (wilting): permanent and temporary. In temporary wilting, the soil has sufficient amount of water. The plant is in turgor in the morning. There is no sign of lack of water at these hours. However, toward noon, increase in air temperature and light intensity causes plant transpiration to peak. As the water taken through the roots up to then is less than the water lost through the leaves, that is the water intake cannot meet the water lost, plasmolysis

occurs and the plant starts wilting. The leaves bend and droop and the shoot tip twists. Towards the evening, as the adverse conditions such as excessive heat and light intensity are removed, the water balance of the plant is established again. Water taken in becomes more than the water lost, plant cells are filled up with water and turgor builds up. Consequently, the leaves and shoots of the plant become tenser and upright. This wilting of the plant is referred as “Temporary Wilting” and this process is “Physiological Drought”.

If the plant exhibits wilting under normal conditions in the morning and evening, this is referred as “Permanent Wilting”. Permanent wilting is observed when the water in the soil is reduced, causing the plant growth slow down an even stop. Firstly, the leaves of the plant droop, twist, and then their colour darkens. Subsequently, the leaves become yellow and defoliation accelerates, starting at the bottom. Shoot tips dry out. If lack of water continues, the plant dries completely out.

Sometimes, although there is water in the soil and weather conditions are suitable for plant growth, permanent wilting may be observed in plants. This wilting is not due to lack of water. In such wilting, there may be a disease on the plant, such as root diseases, hazardous organisms that cause root diseases or even death, any disease or mechanical damage in the plant transport tubes. Besides these, conditions such as increase of the salinity of soil, lack of air in the soil, inadequate soil temperature may have a similar effect.

On the other hand, distribution of the plant roots in water depends on the structure and chemical, physical and biological properties of soil, and on water and nutrients. Under normal conditions, all plants express their genetic characteristics. The roots are appropriately distributed and reach to certain distances. Giving the tomato plant as an example, in the summer months, about 50% of the roots of the tomato plant reach to the first 50-80 cm depth from the soil surface and 80-100 cm width. 20-30% of the plant roots may reach 80-100 cm depth and 100-120 cm width, and the remaining 10-20% part may reach to depths below 120 cm and to 150 cm and sometimes even up to 200 cm width under some conditions. In a greenhouse which is not heated in the winter months, the distribution of the roots in depth and width suddenly decreases significantly, stopping at 20-30 cm depth and 30-50 cm width. When the greenhouse is heated, the distribution will increase somewhat to reach about 30-50 cm depth and 40-80 cm width. In short, when the environmental conditions change, the distribution rate also changes and the genetic characteristics may not reach to sizes it should.

In addition, the growth of the roots in depth and width may differ depending on the development stage of the plant. When the young tomato plant is about 1-1.5 months old, it may distribute its roots at most to a width of 20-30 cm. When 2-3 months old, this may increase to 30-50 cm and with time may reach the above mentioned sizes.

Plants may be divided into three groups according to their rooting depths as deep-, medium- and shallow-rooted. In general, plants that reach up to 60 cm and root on the average between 20-30 cm are shallow-rooted plants; those that reach up to 120 cm and root on the average between 40-80 cm are medium-rooted vegetables; and those that reach up to 180 cm or more and root on the average between 100-150 cm are deep-rooted plants. Plants may be grouped as [in Figure 1](#) according to root depths and the amount of water they consume during the overall development period under normal conditions.

4. IRRIGATION SYSTEM AND METHODS

The irrigation water that plants need to continue normal development and yield product is taken from the water resource via some structures, is conveyed to the area to be irrigated and is distributed within the area to the root zones of the plants. This whole structure is called the irrigation system and in such structures the water is controlled as well as being taken from the resource, conveyed and distributed. Irrigation systems are classified as follows:

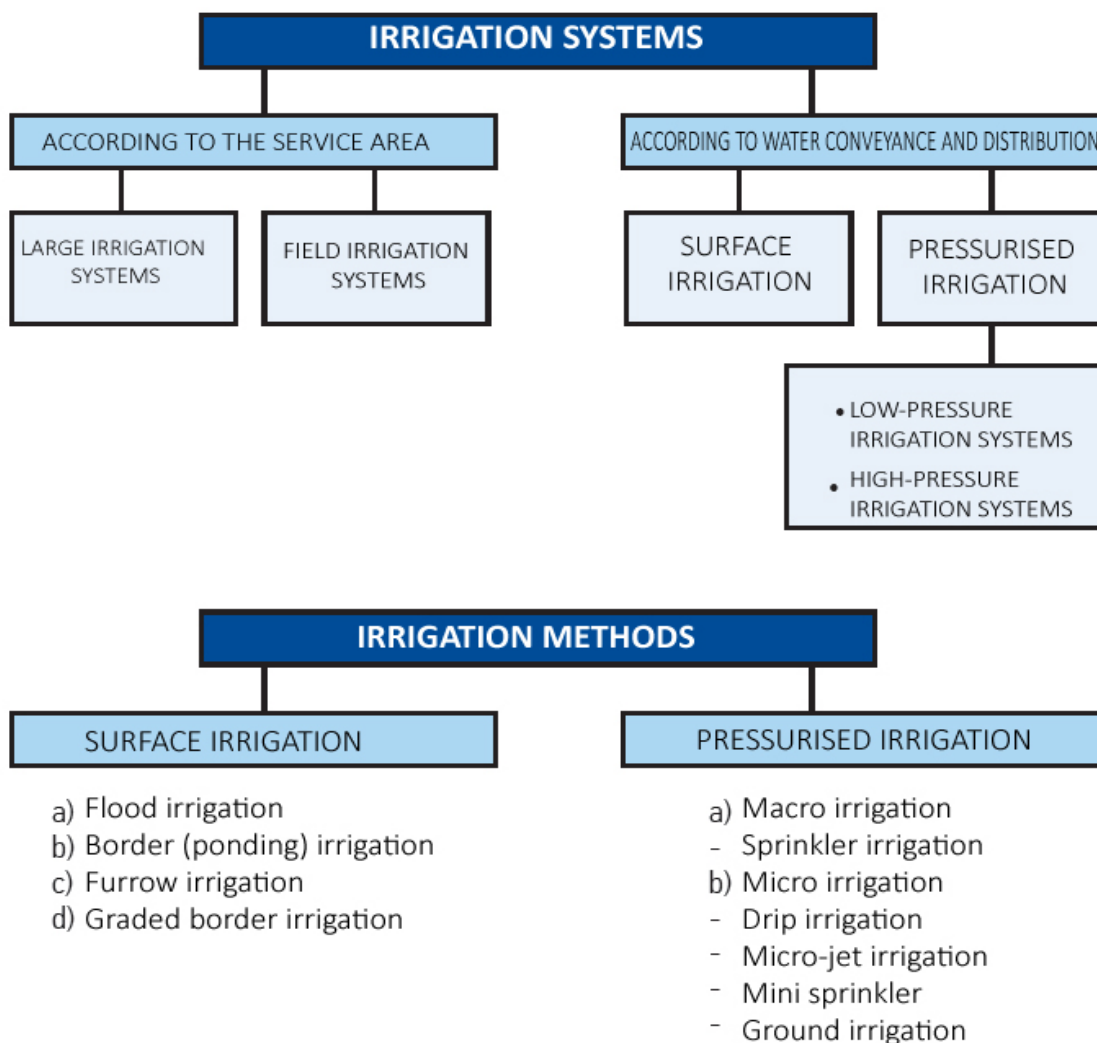

Figure 4.1. Classification of irrigation methods

The expression “irrigation water” defines the way the water brought from the water resource to the field is given to the root zone of the plant. Irrigation methods can be classified as surface irrigation methods and pressurised irrigation methods (Figure 4.1). In surface irrigation methods, the water moves on the surface of the land in the direction of a certain slope under the influence of gravity and doing this, it penetrates into the soil by infiltration and the desired amount of irrigation water is stored in the root zone of the plant.

On the other hand, in pressurised irrigation methods, the irrigation water is conveyed and distributed from the resource to the plant in pressurised pipes. The irrigation water under pressure is given over the plant just as in natural rainfall or to the soil surface as in drip irrigation.

4.1. CHOOSING THE APPROPRIATE IRRIGATION METHOD

In irrigation applications, when a certain land is to be irrigated, firstly the most suitable irrigation method is chosen and then the system that this method entails is planned, installed and operated. In general, the irrigation method to be chosen should fulfil the requirements given below:

- A uniform water distribution,
- Deep penetration and minimising losses such as surface flows,
- Not causing soil erosion,
- Not preventing agricultural mechanisation,
- Helping to wash out the salts in fields where there is a problem of salinity.

However, it is not possible an irrigation method that can meet all these requirements. Irrigation methods have advantages and disadvantages when compared to each other.

The factors influencing the choice of the irrigation method are given in Figure 4.2. As can be seen from this figure, such factors may be examined in 7 groups: water resource and the characteristics of the irrigation water, soil properties, topographical properties, climate characteristics, plant characteristics, and the economic, social and cultural status.

There are path factors in choosing the irrigation method. As a result of comparative assessment of these factors as given in Figure 4.1, the irrigation method to be chosen will be revealed to a great extent.

4.1.1. Water Resource and the Characteristics of the Irrigation Water

The kind and distance of the water resource

If the irrigation water is diverted from some stream, etc, it is generally conveyed via an open canal system and surface irrigation methods are used. If the water resource is high enough to ensure the desired pressure, pressurised irrigation methods should be preferred since it will not require an extra energy cost. If water is supplied from deep wells, the unit cost of water will be rather high. In such a case pressurised irrigation methods, where a high irrigation efficiency is ensured, should be preferred.

Flow rate of the water resource

In the border (ponding) and graded border irrigation methods a high amount of water is required. Thus, in case the water flow rate at the start of the field entrance is less than 30 l/s, furrow irrigation or pressurised irrigation must be chosen.

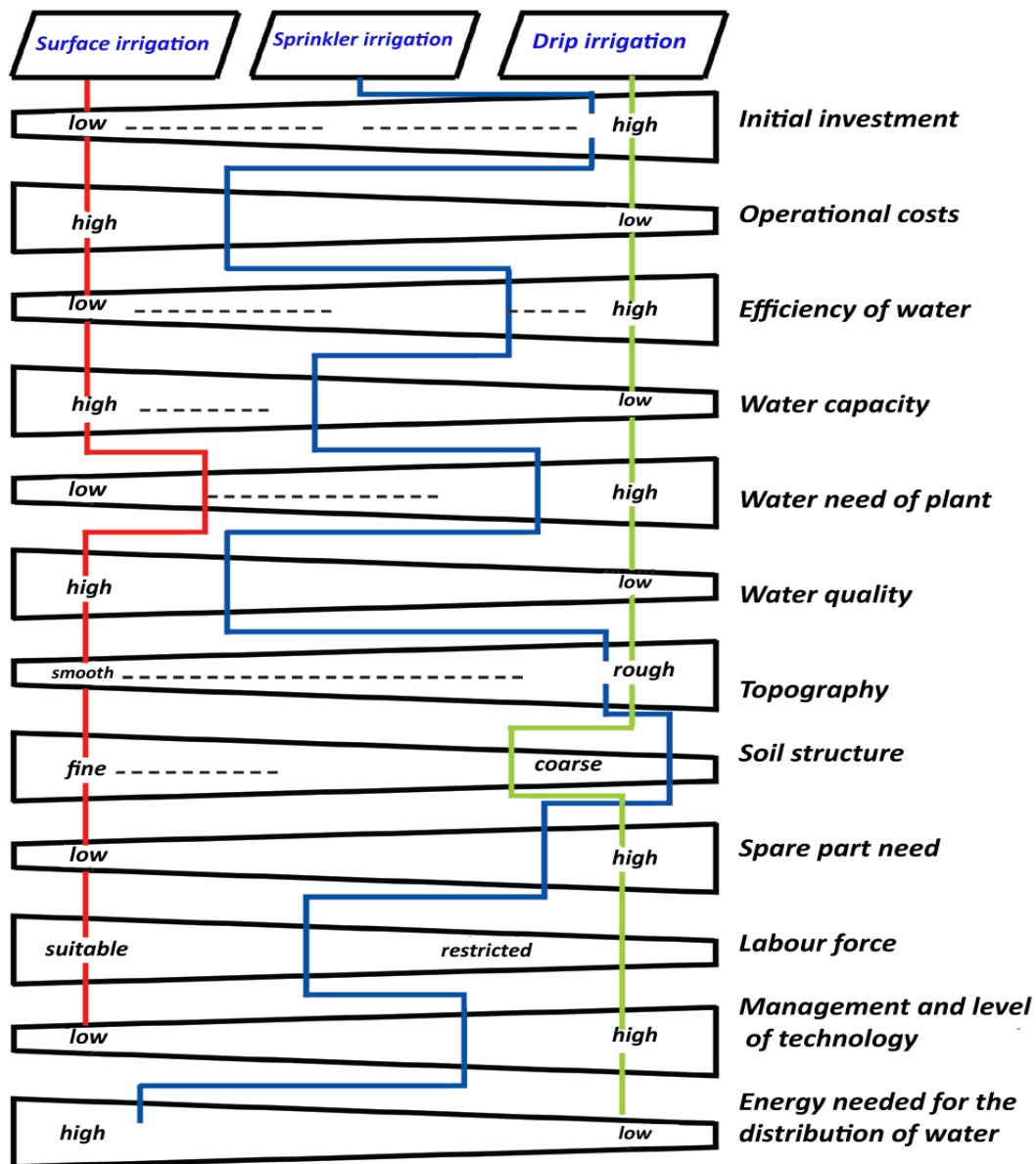

Figure 4.1. Factors in choosing the irrigation method

Water limitation

Since a high water application efficiency is necessary when the land to be irrigated is large and water is low in amount, generally pressurised irrigation methods are preferred.

Quality of the irrigation water

The quality of water is generally graded according to its dissolvable salt content. If the irrigation water is salty, this water should be applied to the field in a way that would prevent salt accumulation in the soil. 100 tons of water used in irrigation will contain 50-1 800 kg salt. Thus, in salty soils, border or graded border irrigation method is used in general to wash away these salts. As only the inside of the furrows are wetted in furrow irrigation, salt moves to the ridges, where it accumulates. Therefore, furrow irrigation is not recommended in salty soils. In case the irrigation water contains too much sediment, it is inconvenient to use pressurised irrigation methods, because a filter unit, which is rather expensive, will be required to clean the water.

TABLES FOR ASSESSMENT OF IRRIGATION WATER ANALYSIS RESULTS

SALINITY	
Class	Explanation
T1 LOW SALINITY WATER	May be used for irrigation of all kinds of plants. As long as the permeability of the soil is not too low, it will not create salinity in soil.
T2 MEDIUM SALINITY WATER	May be used for irrigation of all kinds of plants except those sensitive to salinity. In fields where permeability of the soil is good or medium, special salinity control measures will not be necessary.
T3 HIGH SALINITY WATER	May be used for irrigation of plants resistant to salinity. This water requires special salinity control measures even under sufficient permeability and drainage conditions. It should not be used on soil where drainage is not complete.
T4 VERY HIGH SALINITY WATER	Not suitable for irrigation under normal conditions. However, may be used with special salinity control measures where plants that are very resistant to salinity are chosen and the need for washing is considered, and where the soil has very good drainage and permeability.

ALKALINITY

Class	Explanation
A1 LOW SODICITY WATER	May be used for irrigation for almost all soils. The risk to cause hazardous alkalinity is very low. However, it is possible that plants sensitive to alkalinity such as stone fruits are effected.
A2 MEDIUM SODICITY WATER	A risk of alkalinity that can be felt in soils with fine structure (clayey soils having high cation exchange capacity) arises, especially under low washing conditions. If there is gypsum in the soil, the risk will be less. These waters may be used for coarse structured (sandy) soils and organic soils (peat bed) with good permeability.
A3 HIGH SODICITY WATER	Creates hazardous alkalinity in most soils. Requires special measures such as good drainage, much washing and organic matter addition. This water may not cause a hazardous alkalinity in soils containing gypsum. Addition of some chemicals may be necessary to replace exchangeable sodium with calcium. However, in waters with very high salinity, addition of chemicals may not be possible.
A4 VERY SODICITY WATER	Generally, it is not used in irrigation. However, it may be used when it has low or medium salt content provided that the soil contains dissolved calcium or that improving matter such as gypsum are added.

CLASSIFICATION OF IRRIGATION WATERS IN ACCORDANCE WITH ELECTRICAL CONDUCTIVITY

E.C. (dS/m)	Class
0,,250 0.250-0.750 0.750-2.250 2.250 +	T1 (Low salinity) T2 (Medium salinity) T3 (High salinity) T4 (Very high salinity)
SAR	Class
0-10 10-18 18-26 26	A1 (Low sodicity) A2 (Medium sodicity) A3 (High sodicity) A4 (Very high sodicity)

REMAINING SODIUM CARBONATE (RSC)

May not be used for irrigation if > 2.5 me/lt
May cause damage if 1.25- 2.5 me/lt
May be used for irrigation if < 1.25 me/lt

SODIUM AND CHLORINE CONTENT

SODIUM (%)	CHLORIDE (me/lt)	CLASS
< 20	<4	VERY GOOD
20-40	4-7	GOOD
40-60	7-12	MAY BE USED
60-80	12-20	DOUBTFUL
>80	>20	MAY NOT BE USED

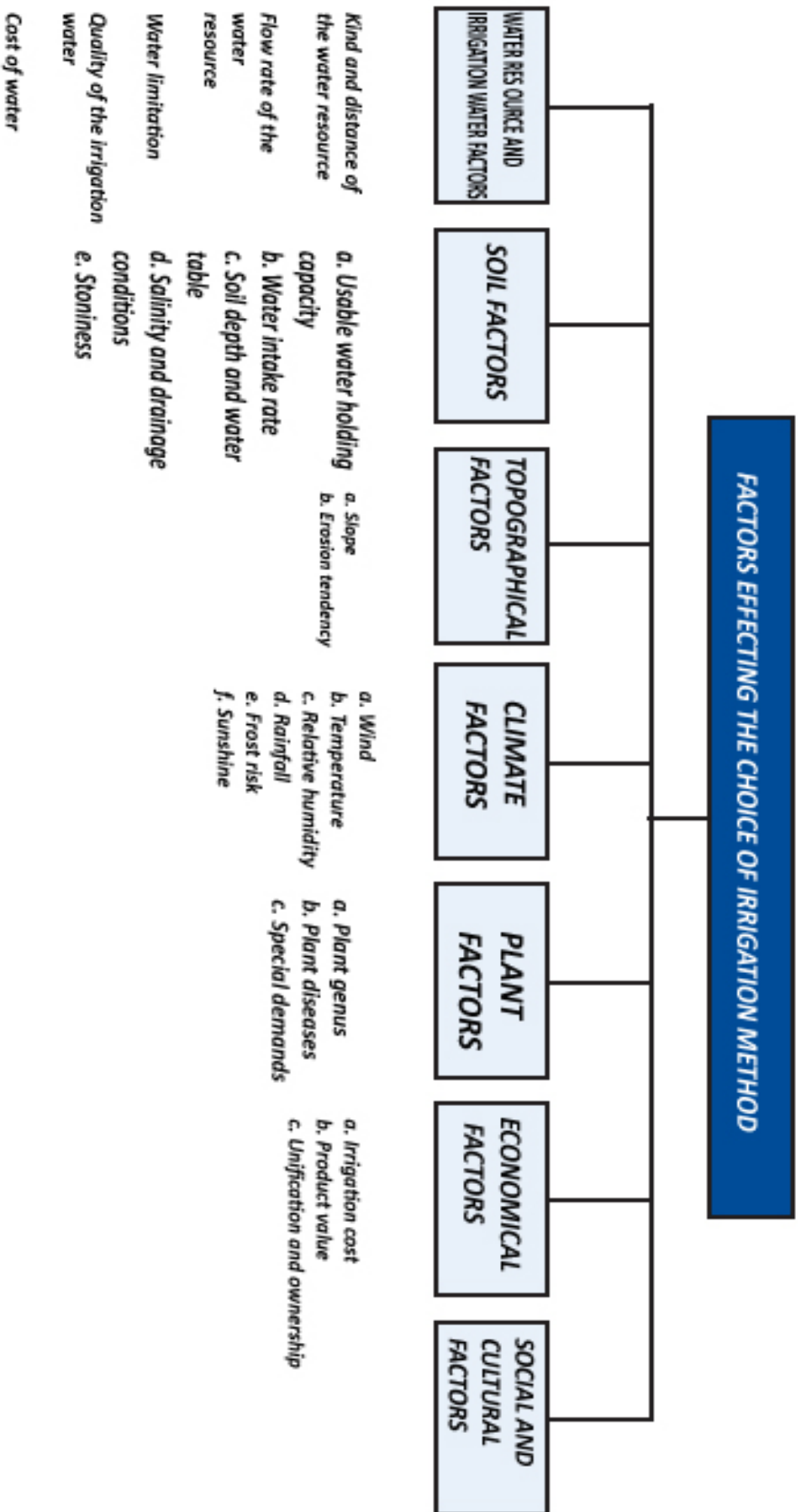

Figure 4.2 : Factors effecting the choice of irrigation method

4.1.2 Soil characteristics

Usable water holding capacity; Ample amount of water can be applied with big irrigation spaces during each irrigation procedure for the soils with high usable water holding capacity. Relatively high irrigation efficiency can be obtained with the surface irrigation methods in these conditions. In sandy soils, which have low usable water holding capacity, on the other hand, irrigation should be made with small spaces and with small amounts of water during each irrigation procedure. Since surface irrigation methods will have low efficiency, it will be better to choose pressurised irrigation methods in this case.

Infiltration rate; This is one of the most important factors in selecting irrigation methods. Infiltration rate is an important factor to be taken into consideration while choosing the irrigation method, choosing the appropriate border and furrow sizes in surface irrigation methods, for the spaces of sprinkler nozzles in sprinkler irrigation method and for determining the speed of sprinkling. Generally, low infiltration rate allows larger border and furrow sizes in surface irrigation methods. In cases of high infiltration rate, on the other hand, the infiltration losses are high and it will be necessary to reduce the sizes. Also, losses in the surface flows will increase if the infiltration rate is very low in sloping lands. If the infiltration rate of the soil is high than 75 mm/h (sandy soils) pressurised irrigation methods are preferred. Generally, surface irrigation methods will be more appropriate if the water infiltration rate is lower than 12.5 mm/h since quite long flow lengths can be obtained. Other factors will affect the selection of the irrigation method if this value is between 12.5-75 mm.

Soil depth and groundwater; Land levelling is harmful for the shallow soils, in which effective soil depth is low or the groundwater is at a high level since an excavation will lower soil depth even more. Also, it is necessary to make a controlled water application which will prevent infiltration into deeper levels. If water is applied at an excess level, the plant roots will stop developing since groundwater will rise to and stay for a long time in the area of plant roots. For this reason, pressurised irrigation methods should be preferred in shallow soils, in which effective soil depth is low or the groundwater is at a high level.

Salinity and drainage conditions; In addition to irrigation water, washing water is also used while irrigating saline soils. Washing water dissolves the salts and carries them to the lower soil layers making salinity rate do drop in the plant root zone. The best methods to be used in this case is border (ponding) irrigation method if there is a drainage system. Drip irrigation method will also give good results while irrigating saline soils. The water coming out of the dripper dissolves and carries the salts while moving towards the perimeter of the wet volume formed by the dripper. The plant carries on its normal development in the relatively lower salt concentration area since salts concentrate on wet area perimeter. However, it will be necessary for these salts to be washed form time to time.

Furrow and ground irrigation methods should be avoided while irrigating salty waters since a part of the water applied with these methods will move up from the soil layer and cause salt to accumulate in the root zone.

Stoniness; Levelling will be difficult and removal of the stones will be expensive or even impossible for very stony soils. Also, pressure irrigation methods can be preferred in stony soils instead of surface irrigation methods since it is difficult to form soil levees in borders or furrows.

4.1.3 Topographical Characteristics

Slope level; almost all kinds of irrigation method can be used in lands with low slope. Furrow irrigation method among surface irrigation methods can be used in parallel with levelling curves if the soil has a high slope but is uniform. Other than that, it is necessary to prefer pressure irrigation methods in steep lands with high slope.

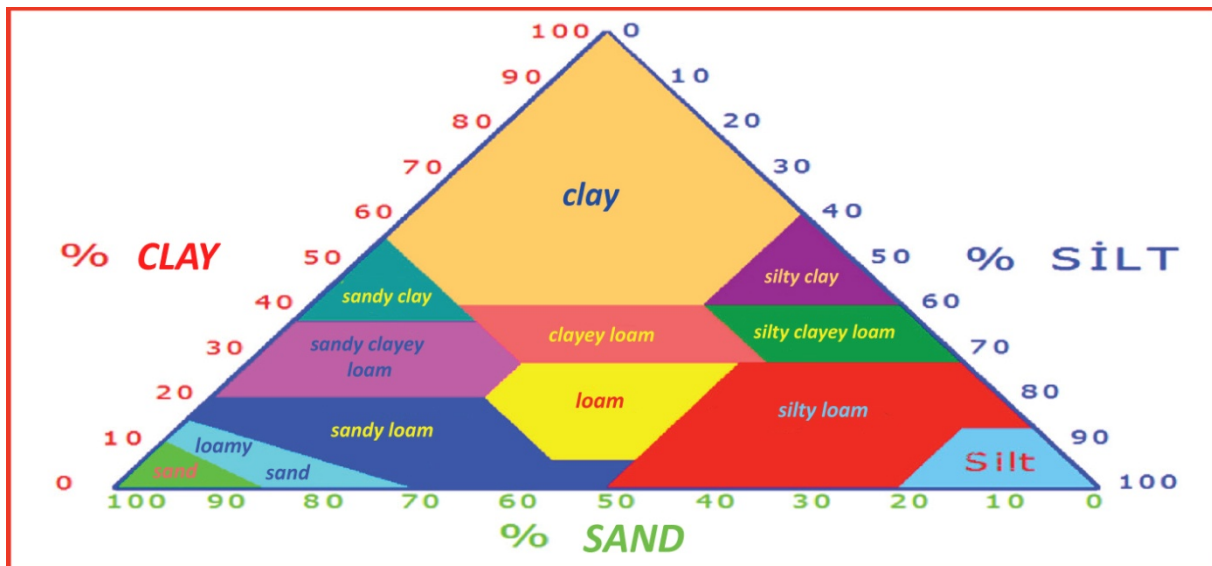

Erodibility; Utmost attention should be paid while applying surface watering methods during the irrigation of erosive soils. The slope should be very low or it should be given in a way that it will be in parallel with water levelling curves. The most appropriate irrigation method in terms of erosion control is pressure irrigation method. However, the system should be operated at a high level of pressure in a way to disintegrate the water drops while sprinkler irrigation is made.

4.1.4. Climatic Characteristics

Wind; It is harmful to use sprinkler irrigation method in the areas where the wind speed is high and the duration of the wind is long. The wind adversely affects water distribution, increases the evaporation losses and reduces the efficiency of irrigation in sprinkler irrigation.

Temperature; High air temperature directly affects the evaporation losses in the irrigation system. These losses are at a high level in sprinkler irrigation method. This rate can go up to 15% of the applied water. If surface irrigation is applied in the same conditions, the evaporation loss remains around 2% when the amount of water is 10 cm.

Relative humidity; Sprinkler irrigation method may not be appropriate since evaporation losses will occur at a high level in places where relative humidity is low. Also, in addition to affecting evaporation, high temperature and low relative humidity will increase the transpiration amount, hence, water consumption of a plant. An increase in water consumption, on the other hand, needs more water to be applied during each irrigation procedure. The most appropriate irrigation method for these conditions is the surface irrigation method.

Rainfall; Irrigation is done only in dry periods in the areas where an important part of the plants' water needs are covered by precipitation during the growth season of the plants. The most appropriate method for this is the sprinkler irrigation method which does not require land levelling and irrigation channels at the beginning of the fields.

Frost hazard; Some precautions are taken to protect plants of higher economic value in the areas where hazardous late frosts may be seen especially during spring. One of these precautions is the sprinkler irrigation method. Both protection from frost and irrigation can be done using the same system in these areas.

4.1.5. Plant Characteristics

Plant type; It is difficult to apply sprinkler and border irrigation methods for tall plants like corn, sunflower etc. since long riser pipes will be necessary to place the sprinkler nozzles above the height of the plant. Similarly, it is difficult to work among dense and tall plants. Furrow irrigation method can be preferred under these conditions. Irrigation should be done without allowing the moisture in the soil to decrease much for greenhouse growing or with the plants with high profitability. Drip irrigation method is the most appropriate method for this. Surface irrigation methods may be effective with deep-rooted plants since lots of water is applied with large intervals every time. Pressure irrigation methods should be preferred for plants with outcrop roots, on the other hand, since low amounts of water are applied with closer intervals.

Plant diseases; Sprinkler irrigation may cause an effective agricultural plant protection since the leaves get wet and this provides a suitable environment for plant diseases. In addition to that, sprinkler irrigation should not be done for a certain period of time after agricultural disinfection and during pollination. Drip irrigation, in which soil surface is not completely soaked, or furrow irrigation should be preferred for greenhouse growing, in which ventilation is not provided sufficiently. Otherwise, it will be easier for diseases to emerge and spread since humidity rate will increase. Also, furrow irrigation method, in which plant root crowns do not contact water, should be preferred while irrigating the plants that are sensitive for root crown diseases.

Special requirements; Irrigation method is directly decided for some plants without taking into consideration other factors. Irrigation of paddy with border (ponding) method is the best example for this. Also, sprinkler or surface irrigation methods increase productivity in the irrigation of sugar beet.

4.1.6. Economic conditions

Cost of irrigation; First establishment costs are higher in pressure irrigation methods compared to surface irrigation methods which do not require heavy levelling or terracing and the operational costs differ from region to region and from time to time according to energy costs.

Product value; Pressure irrigation methods can be more economic since more productivity will be obtained with a product of high market value even if the first investments costs are high. For example, drip irrigation is used in almost all the greenhouses and strawberry fields in our country.

4.1.7 Social and cultural situation

Habits, traditions, cultural levels and agricultural education levels of the farmers are important in selection of the irrigation method. Farmers in our country prefer surface irrigation methods, which are easy for them and which do not require much technical knowledge, although they have low efficiency. However, it is easier for the use of pressure irrigation methods to spread in the cases when the water is scarce and expensive. Use of pressure irrigation methods has been spreading rapidly in our country in the recent years.

4.2. FLOOD IRRIGATION METHOD

In the flood irrigation method, the water diverted from the field entrance channels is left to randomly distribute on the field surface. Water is made available on the field surface until the

desired amount infiltrates into the root zone. For the flood irrigation method to be successful, the field surface must be very smooth and must have no slope perpendicular to the irrigation direction. Theoretically, it is envisaged that water will flow to cover the field surface as a layer.

However, this condition does not generally happen in practice. Water moves opening a path to itself and mostly it distributes unevenly. A different application of the flood irrigation method is that the water in the channels at the field entrances is caused to overflow, and the overflowing water spreads on the field. To this end, the field part beside the channel is lowered to ensure that water enters the field. This irrigation method may be used when the field slopes in the direction of irrigation. It is applied generally in fields at the hill foots which have a slope of 15%. The field entrance channels are made with very little slope parallel to contour lines.

The only main advantage of the flood irrigation method is having very low initial investment cost. In general, it does not require land levelling. On sloping lands, field entrance channels parallel to the contour lines hold the surface waters of the next highest channel and as this water is again used for irrigation, irrigation efficiency relatively increases.

Although flood irrigation method is used in sloping lands, if there is a surface flow due to rainfall, considering erosion control, it must not be used on lands with a slope exceeding 4%.



Flood irrigation method is generally used for irrigation of densely planted plants. A continuous or batch flow may be applied. The purpose in batch irrigation is to maintain water on the field surface for duration T, where this duration is calculated by placing the amount of water to be applied (D) in the additive water intake equation:

$$D = K.Tn$$

Field entrance channels are generally of soil. If the land has tendency for erosion and run-off losses are high, they can be made of concrete. The slope of the channels must not exceed 0.1%. The distance between the channels changes between 25 – 100 m depending on slope and slope uniformity. Flood irrigation method is not highly recommended since it cannot ensure an even water distribution on the field surface and it may give rise to salinity and sodicity problems. However, it may be used when water is abundant and labour costs are low and for plants, the market value of which are not high.

4.3. PONDING IRRIGATION METHODS

In ponding irrigation method, water is ponded in borders or furrows in a short time and when irrigation is completed, water can remain on the soil surface for a long time. Within this duration, water infiltrates into the soil and is stored at the root zone. Ponding the irrigation water in borders is referred to as **border irrigation method**.

4.3.1. Border Irrigation Method: The border irrigation method is the simplest and most common of all the surface irrigation methods (Figure 4.2). This method is used for fields with low levelling cost, especially for soil with low water intake rate, in irrigation of fruit trees, rice, cereals, pastures and fodder, and in improvement of saline – alkaline soils. The borders are formed by making temporary or semi-permanent levees around them. Temporary levees are used for one irrigation or one season. Semi-permanent levees are used for perennial plants grown successively for years at the same place or for rice.

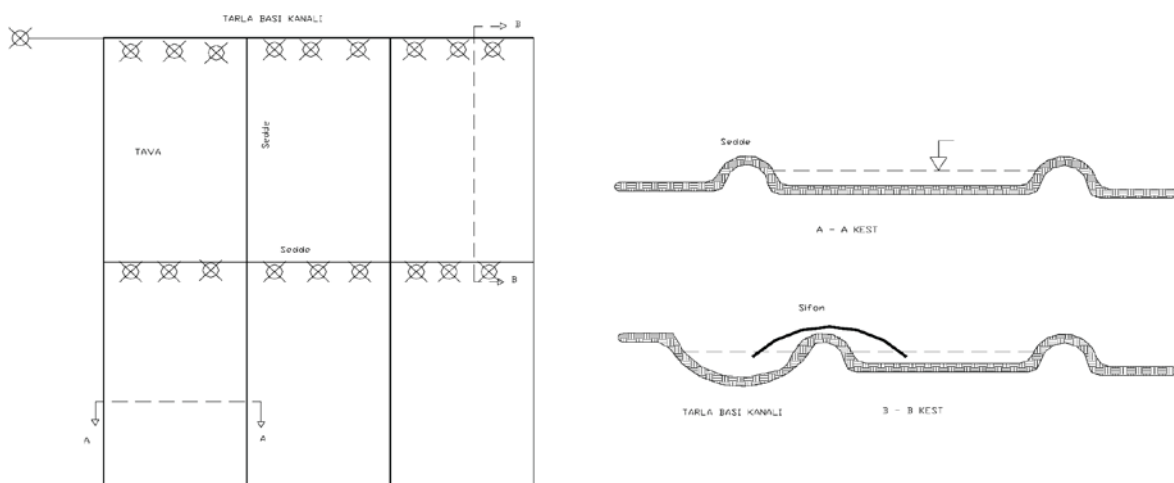

Figure 4.2 : Border Irrigation Method

- a. **Advantages of border irrigation method:** Since there is no surface flow, surface drainage channels are not necessary. Thus, the system cost is low. Amount of water infiltrating deep may be reduced through controlled irrigation. Since there is no surface flow, a high water application efficiency is obtained. There is no need for qualified workers. Rainfall is made use of at the highest level. Salty soils can be washed effectively.
- b. **Factors limiting the application of border irrigation method:** Since the borders must have no slope, this method requires special land levelling. Controlled irrigation is required to prevent deep infiltration. Otherwise, an underground drainage system will be necessary, which will increase the system cost. Since the border flow rate will be high, special structures at the start of the border may be necessary to prevent erosion.
- c. **Border dimensions:** The borders may be formed in various sizes depending on the factors effecting border sizing, and may be between 1-2 m² to 3-4 ha (Figure 4.3). Soil characteristics, flow rate, irrigation depth, land slope, field dimensions and agricultural applications effect the sizing of the borders.
- d. **Soil characteristics:** The border irrigation method is applied to deep soil with relatively high usable water holding capacity and with high-, medium and heavy structure. It generally is not applied to light soil with high water intake rate, and heavy soil with very low water intake rate and high clay content having bleach layer formation tendency.

Therefore, since water infiltrates very rapidly when irrigating sandy soils, the sizes of the borders must be less compared to clayey soils. Since water intake rates in clayey soils is slow, the irrigation water will distribute more rapidly, thus irrigating a wider area. Therefore, when clayey soils are irrigated, the sizes of the borders must be greater.

- e. **Flow rate:** In fields where a higher flow rate can be used for soils which have the same characteristics, the borders may be larger because under these conditions water will spread over the soil surface more rapidly, making it possible to irrigate a larger area.
- f. **Irrigation depth:** Similarly, applying a higher irrigation depth will make it possible to make larger borders, because a higher irrigation depth requires a longer contact time, making it possible to have more time for the water to distribute over the soil surface.
- g. **Slope of the land:** The borders must be plain perpendicular to the direction of irrigation. Parallel to the direction of irrigation, they must be plain or must have a slope such that the height difference between border ends does not exceed half the amount of net irrigation water. Therefore, each border formed is levelled with light levelling machines. At places where the land is plain, the borders may be as large as the flow rate and soil characteristics allow. However, in sloping and rough lands, the land surface must be reformed. In steep and irregular lands, stages or terraces are formed this way, making each border plain within itself (Figure 4.4).

Flow rate (L/s)	Soil type			
	Sand	Sandy - Loamy	Clayey - Loamy	Clayey
15	0.01	0.03	0.06	0.1
30	0.02	0.06	0.02	0.2
60	0.04	0.12	0.24	0.4
90	0.06	0.18	0.36	0.6
120	0.08	0.24	0.48	0.8
150	0.10	0.30	0.60	1.0
180	0.12	0.36	0.72	1.2
210	0.14	0.42	0.84	1.4
240	0.16	0.48	0.96	1.6

Figure 4.3 Recommended border dimensions (ha)

Field slope (%)	Terrace width (m)
0.1	150 – 60
0.2	75 – 30
0.5	30 – 12
1.0	15 – 6
1.5	10 – 4
2.0	7.5 – 3
3.0	5 – 2
4.0	3.5 – 1.5

Figure 4.4. Recommended terrace widths for borders

- h. Agricultural applications:** In most of the developing countries, the farms or the fields are rather small. In such lands, which may be between 1-2 ha or smaller, multiple plant varieties are grown at the same time and land processing, planting and harvesting are carried out by human or animal labour force. For such lands mostly small borders are used because forming and levelling them is rather easy and a small flow rate is sufficient for irrigation. In large, mechanised farms, channels and soil levees hinder machine use. In such farms, the borders must be large enough so that the machine can conveniently move and turn around within the border. In addition, the border width must be multiples of the operation width of the agricultural machines.
- i. Plant characteristics:** The method is generally used in densely planted cereal, fodder plants and pasture plants and orchards. The plants must not be sensitive to diseases caused by wetting the root collar. In the irrigation of field plants, border dimensions are rather large. In the irrigation of orchards, small sized borders that can serve one or a few trees are used (Figure 4.2). Water is given to these borders through large and deep furrows opened between rows of trees.
- j. Soil levees:** These are small barriers or dikes and are structures made around the border to hold water without run-off despite infiltration. The form and sizes of these levees vary depending on:
- Irrigation depth,
 - Air gap
 - Wave movement
 - Machine use.

Levees are generally 150-300 mm high and are made to convey water on the soil surface (irrigation depth 50-200 mm), with a small air gap to stop the water overflowing the levee. In large borders and under windy conditions, the wave movement may pose a big problem. In such cases, the air gap must be larger. The bottom width of the levees is 0.6-1.2 m (Figure 4.3). The levees are larger in rice fields compared to other products, with 400-500 mm height and 1.5-1.8 m bottom width. In mechanised farms, the levees are established carefully so that the agricultural machines are conveniently used over the levees.

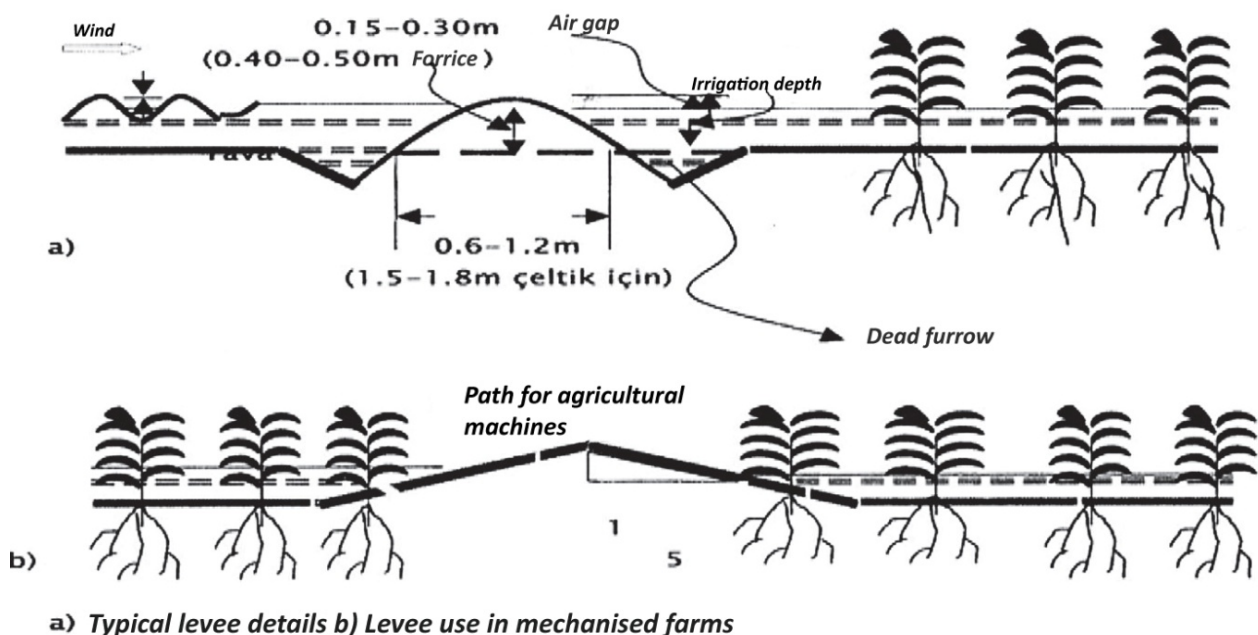

Figure 4.3: Levee Varieties

- k. **Application of the irrigation water:** When borders are being irrigated, water is diverted from the field entrance channel to each border through siphons or pipes. In some farms all the water is given to one border, while in others water is divided to irrigate several borders simultaneously. Whichever method is used, the flow rate must be sufficient to ensure that the water moves rapidly along the field. This will ensure a uniform irrigation. Thus, the borders are filled at the desired border depth and are ponded until water infiltrates into the soil. In this method, there will always be some water loss due to deep infiltration, but when the appropriate flow rate is used, this amount will be rather small.
- l. **Planning the border irrigation method:** The purpose in planning large sized borders is to determine the border dimensions depending on the existing conditions of soil, plant and water resource, identifying the irrigation interval and the amount of water to be applied at each irrigation and to calculate the irrigation duration. Before planning, information such as dimensions, shape and the topographical status of the field, soil structure, usable water holding capacity, plants to be cultivated, consumptive water use, effective root depth, flow rate of the water resource, the quality of the irrigation water, etc. must be gathered. In addition, water intake rate of the soil and the additive water intake equation must be determined through infiltration tests.
- **Net infiltration time:** The net infiltration time is the time during which the amount of net irrigation water to be applied at each irrigation enters into the soil. The additive water intake equation

$$D = K.T^n$$

can be rearranged to get the equation

$$Tn = \left(\frac{dn}{K}\right)^{1/n}$$

from which the net infiltration time can be calculated. In this latter equation:

Tn: Net infiltration time, minutes

dn: The amount of net irrigation water to be applied at each irrigation, cm

K, n: Additive water intake equation constants.

- **Water progress time and water application efficiency:** The time that it takes water given from the field entrance channel to reach the border is referred as the water progress time. There is correlation between the water application efficiency and the water progress time. The water progress time is expressed as the percentage of the net infiltration time:

$$Ti = R Tn$$

where:

Ti: Water progress time, minutes

R: Water progress ratio

Tn: Net infiltration time, minutes

Water progress ratio is the ratio of the water progress time to the net infiltration time. The values of the water progress ratio depending on the water application efficiencies are given in Figure 3.4. In border irrigation method, water application efficiency is generally chosen around 80%; hence, the water progress ratio will be around 60%. In other words, in practice, the water given to the border is desired to reach the end of the border in a duration that is around 60% of the net infiltration time.

In irrigation applications, if the water progress rate is known, the water application efficiency may approximately be found using Figure 4.5. Since the amount of water that has infiltrated deeply if the water application efficiency is especially lower than 70%, an effective underground drainage system must absolutely be installed.

Water application efficiency E _a (%)	Water progress ratio R = T _i / T _n
95	0.16
90	0.28
85	0.40
80	0.58
75	0.80
70	1.08
65	1.45
60	1.90
55	2.45

Figure 4.5 The relationship between the water application efficiency and the water progress ratio in border application

- Border length and border flow rate: The relationship between the water to be given to the border and the border length can be expressed by the following equation:

$$L = \frac{6 \times 10^4 qu Ti}{\frac{aTi^b}{1+b} + c + (1798n^{\frac{1}{2}}qu^{\frac{1}{2}}Ti^{\frac{1}{2}})}$$

where

- L : Border length, m
- qu : Border flow rate unit, m³/s/m
- Ti : Water progress time, minute
- K, n : Additive water intake equation constants.

Using this equation, the most suitable L, qu combination is chosen depending on the field dimensions and the available amount of irrigation water. If qu is known, L can be directly calculated but when L is known qu cannot be directly calculated, and the trial and error method is used.

- **Duration of irrigation:** The duration of irrigation is the time that it the water is given to the border and can be calculated using the following equation:

$$Ta = \frac{dtl}{600qu} \text{ veyya } \frac{dtL}{600quEa}$$

where

- Ta : Irrigation time, minutes
- dt : Total amount of irrigation water to be applied at each application, mm
- L : Border length, m
- qu : Border flow rate unit, m³/s/m

- **Field entrance channel and taking the water into the borders:** The field entrance channel is generally in the shape of a field ditch. When leakage losses are high, a concrete channel may be constructed. Sometimes an embedded concrete pipe or an aluminium pipe line spread on the surface is used. If the field entrance channel will transmit the system flow rate to all borders or water will be given to more than one border simultaneously, it has to be installed to distribute the water evenly. The water level in the channel must be 0.15-0.30 m higher than the field surface depending on the way water is taken in. If possible, the slope of the field entrance channel must not exceed 0.1%. If all the water in the field entrance is to be given to one border, taps with rectangular covers or siphons are commonly used. If water is to be given to more than one border, orifice type taps with covers are preferred to minimise flow rate change due to water load difference. If there is a pipe line at the field entrance, a T piece is placed on the pipe and a valve or a cover is installed to the outlet of the T piece. At the location where water is taken on the borders, the water rate must be less than 1 m/s to prevent erosion. To this end, special structures can be made.

4.3.2. Graded Border Irrigation Method: In the graded border irrigation method, the field to be irrigated is surrounded by soil levees to divide it to narrow and long sub-parcels. These sub-parcels are called graded borders. Water taken to the border from the field entrance channel or from the lateral pipeline progresses along the border and meanwhile it infiltrates into the soil and is stored in the root zone of the plant. After irrigation is complete, as the water draws back along the border, some amount of water also infiltrates into the soil.

The conditions under which this method can be applied is similar to those in the border irrigation method with respect to plant and soil characteristics. With respect to topographical characteristics, again the borders must have no slope in the direction perpendicular to the irrigation direction. However, in the direction of irrigation there will be a slope. Consequently, the width of the border inevitably reduces. The border end is left open and surface drainage channels are established to remove the water coming out of the border. In other words, while water is ponded within the border in the border irrigation method, it is not ponded in the graded border irrigation method. As the border end is open, a certain part of the water is removed from the border end by surface drainage channels (surface flow).

Border irrigation method is preferred over the graded border irrigation method if densely planted plants which are not sensitive to diseases caused by wetting the root collar except for rice and fruit trees are being irrigated, and if in addition there are medium and medium-heavy soils which do not have bleach layer formation tendency, and when the topographical conditions allow land levelling with no perpendicular slope in direction of irrigation since a higher water application efficiency will be obtained under controlled irrigation as there is no surface flow. However, if topographical conditions dictate a slope in the direction of irrigation, the graded border irrigation method is applied.

a. Advantages of the graded border irrigation method:

- Initial installation costs are low.
- Levelling costs can be kept at minimum level by separately levelling each border
- Under conditions of critical surface drainage, a good surface drainage can be formed.

b. Factors limiting the application of the graded border irrigation method: Special land levelling is required since the border has no slope perpendicular to the irrigation direction. A good planning and controlled irrigation is a must to reduce surface flow losses and to increase the water application efficiency. Yet, the water application efficiency is lower than that of the border irrigation method. Since there is surface flow, surface drainage channels must be installed. Special structures may be necessary at the start of the border to prevent erosion.

c. Sizes and shapes: Graded borders are generally rectangular, and may have a length of 100-800 m and a width of 3-30 m. All the factors effecting the sizing and shaping in the border irrigation method have similar effects in the graded border irrigation method. There are no simple calculations as in the graded border irrigation method to help choosing the most suitable graded border sizes for different soil types and unit flow rates. Graded border sizes that are acquired through regional experiences and that may be practical guidelines are given in Figure 4.6.

d. Slope: Ideally, graded borders must have a uniform slope along the length of the border but must not have any slope in width. In graded borders, the minimum slope is generally 0.1%. The maximum slope depends on the risk of soil erosion. This slope may be 2% in clayey soils and 5% in sandy soils, depending on rainfall, soil type and vegetation density (Figure 4.7).

Soil structure	Field slope	Irrigation depth to be applied	Suitable border sizes (m)		Water flow rate given to the border
	(%)	(mm)	Width	Length	(L/s)
COARSE	0.25	50	15	150	225
		100	15	240	200
		150	15	400	170
	1.00	50	12	90	80
		100	12	150	70
		150	12	275	70
	2.00	50	9	60	35
		100	9	90	30
		150	9	180	30
MEDIUM	0.25	50	15	240	200
		100	15	400	100
		150	15	400	170
	1.00	50	12	150	70
		100	12	300	70
		150	12	300	70
	2.00	50	9	90	30
		100	9	180	30
		150	9	300	30
FINE	0.25	50	15	400	115
		100	15	400	70
		150	15	400	42
	1.00	50	12	400	70
		100	12	400	35
		150	12	400	21
	2.00	50	9	400	30
		100	9	400	30
		150	9	400	20

Figure 4.6 Recommended graded border dimensions

Soil Type	Humid regions		Arid regions	
	Bare soil	Good vegetation	Bare soil	Good vegetation
Clayey	0.3	1.0	1.0	2.0
Sandy	0.5	2.0	2.0	5.0

Figure 4.7 Maximum border slope for graded borders

Application of the Irrigation Water

In the irrigation of graded borders, using the appropriate unit flow rate is rather important with respect to soil and land slope. In addition, stopping the water given timely is also very important to fill the soil reservoir with sufficient amount of irrigation water. Otherwise, if this time is not properly set, the water will not reach the end of the border or will be lost by surface flow runoff.

There are some practical experiences acquired within long years, concerning when to stop the water given to the borders depending on soil structure. In accordance with such experiences,

- 1- in clayey soils, the water given to the borders is stopped when it reaches 60% of the border length,
- 2- in loamy soils, the water given to the borders is stopped when it reaches about 70-80% of the border length,
- 3- in sandy soils, the water given to the borders is stopped when it reaches to the end of the border length.

The above rules are only general guidelines in irrigation, to help correctly deciding to stop the water. Despite everything, there may be some amount of surface flow runoff, but this must not exceed 10-15% of the total applied water. Therefore, surface drainage channels must be installed at the end of the border to remove and reuse these runoff waters.

4.4. FURROW IRRIGATION METHOD

In the furrow irrigation method, small shallow channels named furrow are constructed among the rows of crops and water is supplied into these furrows. While the water advances along the furrow, it also penetrates into soil by infiltration and is stored in the root zone of the plant. In the open furrows, the water flowing out of the furrows during the irrigation (runoff) is flown away through or reused as irrigation water within the bounds of possibility. (Figure 4.5)

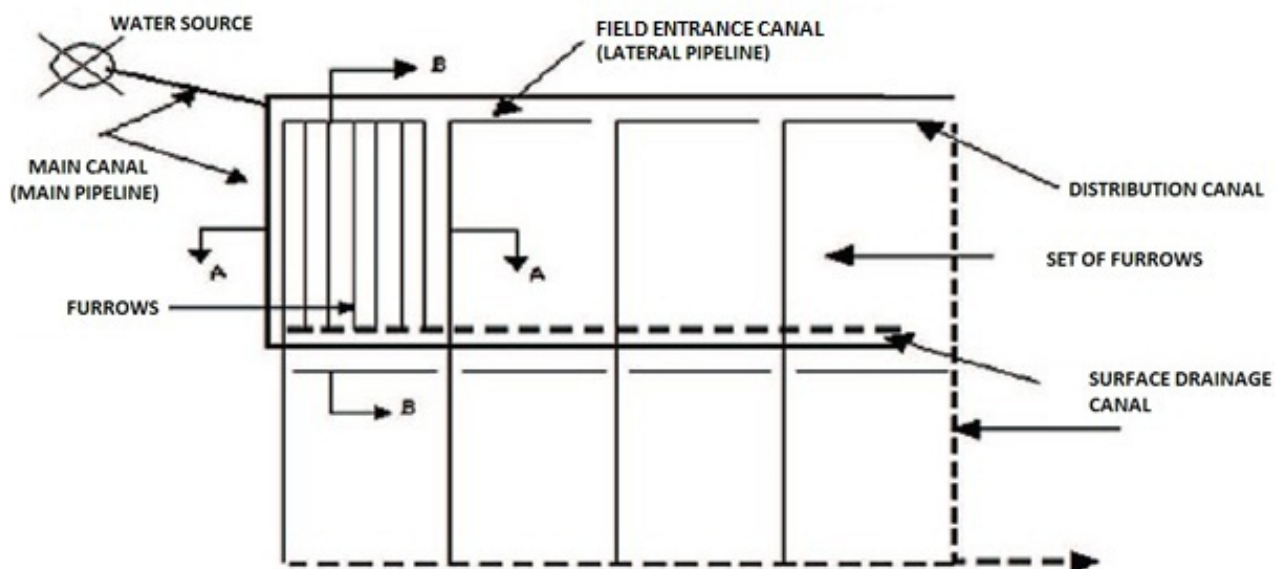

Figure 4.5 Furrow irrigation system elements

The furrow irrigation method is used to irrigate the crops sown or planted in rows and orchards and vineyards. The method is very suitable for the irrigation of the crops which are damaged by wetting the root crown because the crops are placed on the ridges between the furrows and the root crown is not wetted.

a. Advantages of Furrow Irrigation Method

1. Initial installation costs are low.
2. Many crops with different characteristics can be grown without changing the system design, organization and irrigation applications.
3. High level of water application efficiency could be obtained through successful land levelling and irrigation management.
4. As the root crown does not contact water, the plants susceptible to the diseases caused by wet root crowns can be grown.
5. It does not much need for irrigation water and the degree of utilization of irrigation water is high.
6. It can be controllably applied in heavy textured soils that crust and cause cracks.

b. Factors Limiting the Application of Furrow Irrigation Method

1. Surface drainage channels should be constructed to send away the water flowing out of open furrows (runoff).
2. When no measure is taken to reduce runoff or when it is not reused for irrigation, the water application efficiency is low.
3. Land levelling could be required in order to obtain an acceptable level of equal water distribution.
4. Establishment of perforated pipelines is necessary to provide every furrow with an equal amount of water in addition to field entrance channels or lateral pipelines.
5. The salt accumulated on the ridges of furrows could be a problem for the crops susceptible to soil salinity.
6. Under the conditions in which rainfall causes runoff, runoff could become intense in the furrows and cause erosion.

c. Furrow shapes

The shape of furrows is an important element for effective and sufficient furrow irrigation. Furrows are generally constructed in the shape of “V”. Furrow width is 250 – 400 mm and the height varies between 150 – 300 mm depending on the water capacity that the furrow carries and the slope (Figure 4.6). The factors determining the furrow shape are flow rate, soil and crop characteristics.

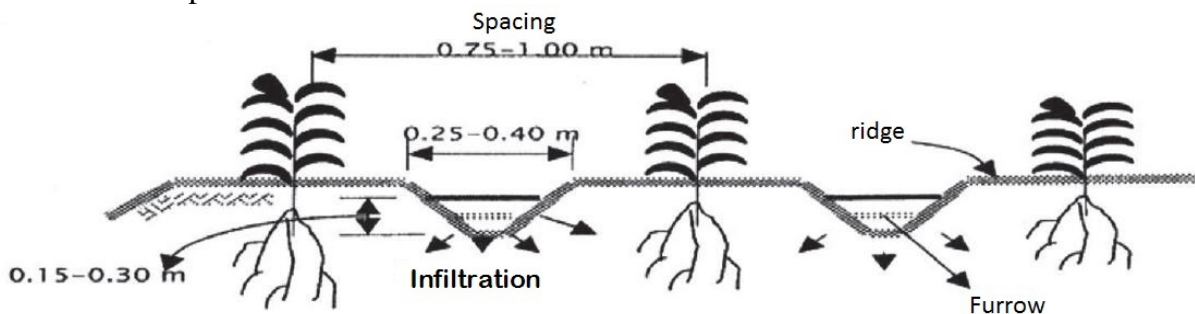

Figure 4.6 General view of furrows



d. Flow rate

Furrows should be like a small channel and every furrow should be as big as the water can be carried without damaging furrows. Furrow flow rates generally vary between 0.2-3.0 L/s.

e. Soil characteristics

Furrow irrigation method can be used for all kinds of soils except for light textured soils whose water intake speed is high (usable water holding capacity is low). It is the most suitable surface irrigation method for heavy textured soils that crust. The reason for this is that soil crusting occurs not on the ridges where the crops grow but in the furrow where water flows and so it does not cause any damages to crops. As water is infiltrated quite slowly in clay soils, furrows should be large and shallow; and as it is the opposite for sandy soils, furrows should be constructed narrow and deep.

f. Crop Characteristics

Shallow furrows are needed for crops with shallow roots and replanted crops. Furrows should be constructed more deeply for crop development and to increase the root deepness.

g. Furrow Spacing

Furrow spacing mainly depends on the move of water in soil, type of crops grown and soil cultivation. A sufficient amount of lateral water movement is required to wet the whole soil profile. Spacing is generally 0.5 m for sandy soils and 1.2 m or longer for clay soils. Row crops are cultivated in spaces of 0.7-1.0 m for suitable planting, harvest and soil cultivation. Besides the fact that tools and machines used for agricultural practices work easily should be also taken into consideration.

h. Furrow length

Factors determining furrow length are soil type, flow rate, irrigation depth and slope. The most ideal furrow lengths determined by taking into consideration these determinants are provided in Chart 4.8.

Slope (%)	Maximum Flowrate (L/s)	Clayey		Loamy			Sandy			
		Average Irrigation Depth (mm)								
		75	150	50	100	150	50	75	100	
0.05	3.0	300	400	120	270	400	60	90	150	
0.1	3.0	340	440	180	340	440	90	120	190	
0.2	2.5	370	470	220	370	470	120	190	250	
0.3	2.0	400	500	280	400	500	150	220	280	
0.5	1.2	400	500	280	370	470	120	190	250	
1.0	0.6	280	400	250	300	370	90	150	220	
1.5	0.5	250	340	220	280	340	80	120	190	
2.0	0.3	220	270	180	250	300	60	90	150	

Chart 4.8 Recommended furrow lengths

i. Topographical Situation

Furrows should ideally have a uniform slope. 0.05% slope is needed in furrows in order to enable water flow along the furrow as well as to drain waste water. Maximum slope varies depending on soil erosion risk. In arid regions maximum furrow slope should be 2% and it should be 0.3% in humid regions especially in regions with heavy rain. There could be slope vertical to the irrigation direction however the slope of field entrance channel should not be more than 0.2% for water to be able to be taken to furrows.

j. Agricultural applications

In terms of agricultural applications, furrows should be as long as possible because this application would allow for reduction of irrigation and drainage expenditures and better practice of the mechanization. Small furrows need more attention because flow has to be switched from one furrow to another very frequently. Using a tractor in farms could be an effective element in determining furrow length. Furrows are pressed via tractor tyres and this slows down the water intake speed of soil. This situation is a good advantage especially in sandy soils and furrow lengths could be increased without extra deep percolation losses. However all the furrows should be exposed to the same pressure otherwise water would advance along furrows in different ratios and this situation would cause a non-uniform irrigation.



Figure 4.7 Water advance in soils pressed by tractor tyres

k. Application of Irrigation Water

Water is provided to multiple furrows at the same time during irrigation. The number of furrows provided water to at the same time constitutes a set of furrows. Therefore the construction of flat distribution channels or perforated pipelines, which serve to every set of furrows, is necessary after field entrance channel or lateral pipeline in furrow irrigation systems. Distribution channels are in the form of the earth channel and water is taken to furrows from the distribution channel via siphons or orifices. When it comes to low pressure pipe systems, perforated pipelines on which there are perforations created in equal spacing to every furrow space at the beginning of every set of furrows are used. These pipelines are generally portable and moved from one set of furrows to another. The biggest problem in furrow irrigation method is runoff losses. Even in furrows prepared very well, this proportion could account for 30% of total flow rate provided to the furrow. Hence, surface drainage channels are needed at the end of the field. But this issue is generally ignored in most of the lands and causes the water to pond at the end of the field and damage water-sensitive crops. Water provided to furrows is stopped 20-30 m before the end of the furrow or reduced 50% depending on soil type and flow rate. Therefore unnecessary water flow to surface drainage channel at the end of the furrow or ponding at the end of the furrow is prevented.

l. Surge Irrigation

The infiltration rate of soil is generally decreased with surge irrigation application and compared to continuous flow, advance is accelerated with this technique and runoff is controlled. Small streams which are necessary for too erosive soils and do not cause erosion require long advance duration, which would cause too deep percolation and low effectiveness. As shown in Figure 4.8, low flow rates can be efficiently advanced by surge irrigation application. This is very important as surge irrigation application is more efficient in light textured soils. Therefore it is possible to irrigate by applying surge irrigation with small streams in long furrows which are more efficient in mechanized farming. When continuous flow is applied with the same low flow rates, it may not be possible for water to reach the end of a long furrow. In surge irrigation application, the total amount of time for wetting and drying is defined as cycle time. After first surge irrigation application, infiltration speed decreases in the successive surge irrigation applications. After a certain number of applications, however, it cannot decrease any more. The infiltration uniformity increases in the furrows where the surge irrigation is applied compared to the continuous irrigation.

Irrigation systems should be automatized in order to apply the surge irrigation technique. The most common system is the bilateral set system tied with T in the middle of a capped pipe. A set of surge irrigation is comprised of a block of equally long furrows at the both sides of the valve. The valve rotates the flow from one side to the other. A valve placed in the middle of a field is sufficient to minimize the costs. In every subsequent irrigation set, a different furrow block at one side of the valve is irrigated.

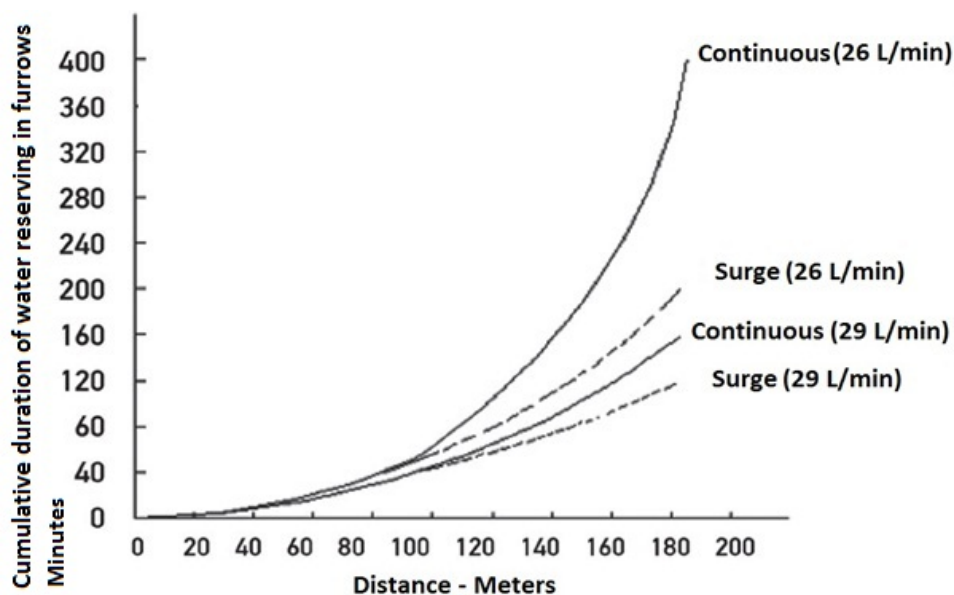

Figure 4.8 Advance curves for surge and continuous flow in a silty – loamy soil

The caps on the pipes are manually opened and closed according to the furrows to be irrigated. Manually controlled or electrically operated valves are used in these systems. There are also valve control systems charged by solar energy. Most of these valves can be programmed as to reduce furrow flow rates after the advance.

m. Furrow Irrigation System Design

The objective of furrow irrigation design is to determine the most suitable furrow spacing, furrow length, furrow flow rate, irrigation duration and irrigation frequency in accordance with the properties of crop to be cultivated, soil type, topographical characteristics, the field size and the amount of available water. The design of furrow irrigation system differs in some ways with respect to steady or variable flow rate and open or closed furrows. In practice, sloping furrows are constructed to be open, flat furrows are to be closed. Water is supplied to open furrows at steady flow rate during irrigation period. If it is possible to reuse the downstream water out of furrow end for irrigation, it is preferred to make arrangement of this kind of furrows. Otherwise, since the amount of the downstream water out of furrows is quite high, the efficiency of water application decreases. Open furrows with variable flow rate are supplied first with a determined flow rate. Upon reaching the end of furrow, the downstream flow rate is generally decreased by 50%, thus, reducing the amount of downstream water out of furrow end the water application efficiency is increased. It is generally not in question to reuse the downstream water out of furrows for irrigation. This water is removed away from the field via surface drainage channels.

Closed furrows, however, are used for totally flat fields or for those whose elevation difference between furrow ends is lower than the depth of water stream to be applied. The furrows are closed-ended. If to be applied on sloping lands water accumulates in the furrow ends and increases the amount of water infiltration through soil in this region. Closed furrows are supplied with water at steady flow rate during irrigation and desired amount of infiltration is enabled by ponding water in furrows. Unlike other irrigation methods, since water does not infiltrate through all over the land surface in furrow irrigation method, infiltration rate measurements made by methods such as using double-cylindrical infiltrometer cannot be applied. The accumulated infiltration depth should be calculated by measuring the amount of inflow and outflow through furrows.

Maximum furrow flow rate in open furrows that will not cause erosion is calculated by the equation below:

$$q = \frac{0.64}{S}$$

q: Maximum furrow flow rate (L/s)

S: Slope of furrow

For furrow irrigation method, the infiltration rate of soil is calculated with the aid of measurement data by the equation below:

$$I = \frac{q_i}{L}$$

In the equation:

I: The infiltration rate of the soil per unit furrow length (L/s/m)

q_i: Difference of inlet and outlet flow rate through furrow (L/S)

L: Length of furrow (m)

The value of accumulated infiltration depths differs according to furrow spacing. In design furrow spacing depends on the crop type to be irrigated.

$$D = \frac{6IT}{w}$$

In the equation;

D : Accumulated infiltration depth, (cm)

I : Infiltration rate (L/s/m)

T : Average duration of time water ponds in the experimental furrow (minutes)

w : Furrow spacing (m)

indicates the abbreviations. As known, if measurement times are marked on apsis and accumulation infiltration depth values are marked on ordinate on log-log paper the linear relation between elapsed time and accumulated infiltration depth will be obtained. The equation of this linearity is shown below:

$$D = KT^n$$

Irrigation duration, in open furrows, is equal to the sum of duration of supplying water to the furrow (irrigation duration), the elapsed time needed for net irrigation water to infiltrate through soil in the furrow end (net infiltration duration) and the time needed for flow to reach to the furrow end. Net infiltration duration is;

$$Tn = \frac{dn}{K^{1/n}}$$

Tn : Net infiltration duration (minutes)

dn : Net amount of irrigation water to be applied for each irrigation, (cm)

K, n : Constants of accumulated infiltration equation

Accordingly **the irrigation duration for open furrows** is calculated by the equation below:

$$Ta = Tn + \frac{Tn}{4}$$

Ta : Irrigation duration for open furrows, (minutes)

Tn : Net infiltration duration, (minutes)

because water is desired to reach to the furrow end in $\frac{1}{4}$ of net infiltration duration in order to achieve sufficient water distribution through soil. In closed furrows when water supply of furrow is stopped significant amount of water stays in furrows since there is no surface runoff and this water gradually infiltrates through soil. Therefore duration of supplying the furrow is shorter than infiltration duration.

That is why the **duration of irrigation in closed furrows** is calculated by the equation below:

$$Ta = \frac{wLdt}{60q}$$

Ta : Irrigation duration for closed furrows, (minutes)

w : Furrow spacing, (m)

L : Furrow length, (m)

dt : Total amount of irrigation water to be applied for each irrigation, (mm)

q : Furrow flow rate, (L/s)

Furrow length and furrow flow rate: In water advance curve graphics (Figure 4.9) previously obtained by field tests, the value of $Tn/4$, which indicates the time for water to reach a furrow end, is marked on ordinate. A parallel line to apsis is drawn from this value. The verticals drawn down from the points where this parallel line intersects with curves results in the maximum length of a furrow for each furrow flow rate. Design of furrow length and flow rate is decided by comparing parcel dimensions and these maximum furrow lengths.

Total amount of irrigation water to be applied for each irrigation

In the end of the furrow, in order to store desired water around the root zone, sufficient amount of water should be supplied to maintain both deep percolation and surface runoff. In furrow irrigation method, total amount of irrigation water to be applied for each irrigation is calculated by the equations below:

In open furrows with steady flow rate;
$$dt = \frac{60qTa}{wL}$$

In furrows with variable flow rate;
$$dt = \frac{60}{wL} \left(q \frac{Tn}{4} + \frac{q}{2} + Tn \right)$$

In closed furrows;
$$dt = 10 K (1.25Tn)^n$$

In these equations;

dt : Total amount of irrigation water to be applied for each irrigation, (cm)

q : Furrow flow rate, (L/s)

Ta : Irrigation duration, (minutes)

w : Furrow spacing, (m)

L : Furrow length, (m)

Tn : Net infiltration duration, (minutes)

K, n : Constants of accumulated infiltration equation indicates the abbreviations.

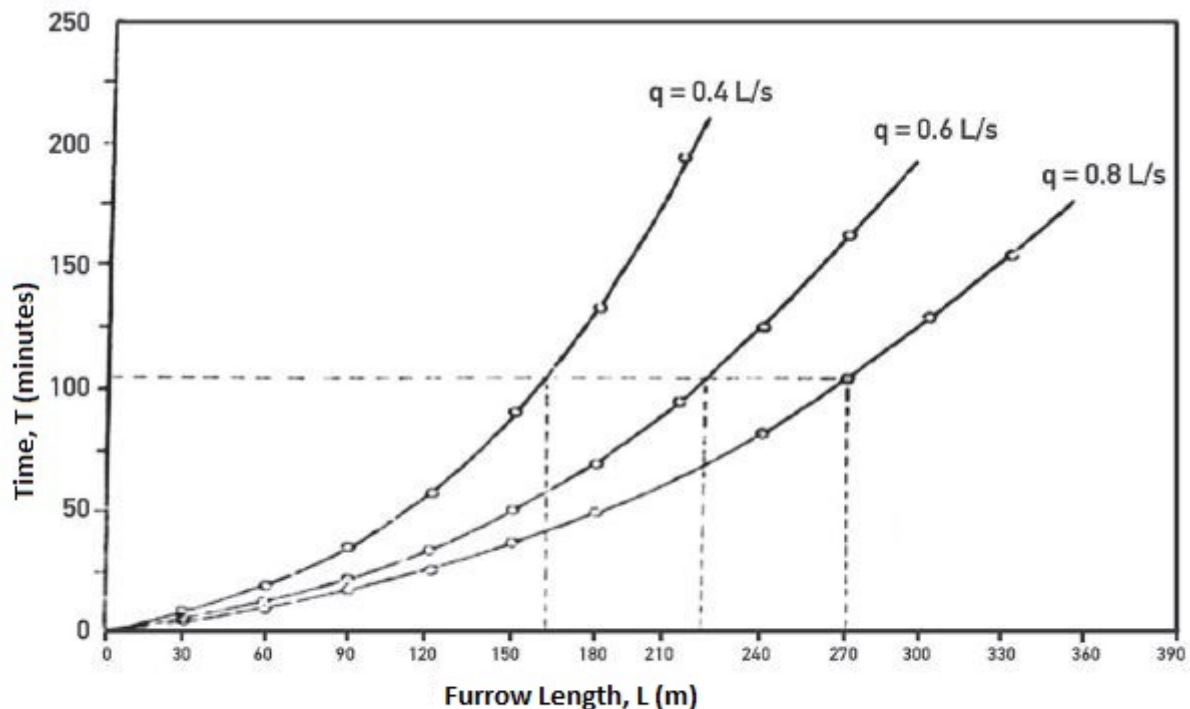

Figure 4.9 Water advance curves for open furrow design

Water application efficiency is calculated by the equation below:

$$Ea = 100 \frac{dn}{dt}$$

In the equation;

Ea : Water application efficiency, (%)

- d_n : Net amount of irrigation water to be applied for each irrigation, (mm)
 d_t : Total amount of irrigation water to be applied for each irrigation, (mm)

Surface runoff and the amount of deep percolation: Surface runoff occurs only in open furrows and is calculated by the equation below:

$$d_{ya} = d_t - d_n - d_s$$

Average amount of deep percolation is calculated in open furrows by the equation below;

$$d_s = K(0.125Tn)^{n10}$$

in closed furrows, however, by the equation below.

$$d_s = d_t - d_n$$

In these equations;

- d_{ya} : Surface runoff, (mm)
 d_t : Total amount of water, (mm)
 d_n : Net amount of water, (mm)
 d_s : Amount of deep percolation, (cm)
 Tn : Net infiltration duration, (minutes)
 K, n : Constants of accumulated infiltration equation, indicates the abbreviations.

4.5 SPRINKLER IRRIGATION METHOD

Sprinkler nozzles are placed with certain spaces on the land to be irrigated in the sprinkler irrigation method. Irrigation water is given from the sprinkler nozzles to the atmosphere by being sprayed under pressure. The water falls on the surface of the soil from here, infiltrates into the soil and is stored in the root zone of the plant. This kind of irrigation is called sprinkler irrigation (raining irrigation) since it looks like natural precipitation in a way. Irrigation procedure is carried on until the desired amount of water is stored in the plants' root zone.

In order to be able to spray the water from the nozzles under pressure, it is necessary that the water to be is conveyed and distributed with pressurized pipelines starting from the source until the irrigation nozzles and that the system pressure is ensured by means of a pump unit or gravity.



Advantages of the Sprinkler Irrigation Method

- The advantages of the sprinkler irrigation method, especially when compared to surface irrigation methods, are specified below. There is no need to level agricultural lands with smooth surfaces.
- High water application efficiency is ensured in waters with light structures and high water intake rate.
- Irrigation can be made in a controlled manner without forming underground water or raising underground water in the shallow soils in which impermeable layer or the underground water is close.
- Water application efficiency is generally higher since water distribution is provided more equally at every corner of the irrigated land and there is no surface flow. Also, there are no conveyance losses since water is conveyed by pressurized pipelines. As a result of these, water efficiency will be higher. This reduces the need for irrigation water per unit area and the system flow rate. Larger areas may be irrigated with the available water especially under limited water source conditions.
- Erosion problem may be eliminated with planning and implementation appropriate for the technique.
- Non-agricultural areas are scarcer and mechanised agricultural procedures can be made more easily since pipelines are buried or, if they are laid on the surface, they cover less space compared to open channels.
- Irrigation can be made easily and labour costs are reduced.
- Plant nutrient elements and some agricultural pesticides used for soil diseases and pests can be

given with the irrigation water in the sprinkler irrigation method when especially fruit trees are irrigated from under the crown and the leaves are not soaked.

- Some vegetables and fruit trees with high economic value can be protected from frost.

Factors Limiting the Application of Sprinkler irrigation Method

There are some factors limiting the application of the sprinkler irrigation method. These are explained below.

- Establishment costs of sprinkler irrigation systems are generally higher compared to surface irrigation systems. For this reason, the system should be planned and designed in a way that will require the lowest costs, provided that the design is appropriate for the technique.
- Generally a pump unit is required to provide the operating pressure. Therefore, it will be necessary to supply power constantly. This increases the operating costs.
- High wind speed and long blowing times adversely effect the distribution of water. This problem can be reduced at a certain rate by making irrigation during hours in which the wind speed is low or placing lateral pipelines in a way that they will stand in a right angle to the direction of the effective wind.
- High temperature increases evaporation losses and causes water application efficiency to drop. Making irrigation during the night in the areas where the temperature is high during the day may eliminate this problem to a certain extent.
- Irrigation made during the pollination period of the plants decreases the fructification rate and productivity. For this reason, irrigation program should be applied in a way to not to irrigate during the pollination period.
- Some plant diseases may spread since plant leaves are soaked. For this reason, it is not right to use sprinkler irrigation method to irrigate plants sensitive to diseases resulting from soaking the leaves.
- If irrigation is completed during the daytime, water drops left on the plants' leaves will act as a lens and focus the sunlight. This may cause the leaves to burn. For this reason, it will be convenient to plan irrigation in a way to be completed after the sunset.
- The same problem may occur if salty water is used for irrigation. Grains of salt are left on the leaves after the irrigation is completed and the water on the leaves evaporate, and such grains may cause the leaves to burn. For this reason, while applying sprinkler irrigation, irrigation water classified as the 3rd class in terms of salinity should not be used unless obliged to.

Conditions under which Sprinkler Irrigation Method Can Be Applied

The soil, topography, plant and water source characteristics with which sprinkler irrigation method can be used are explained below.

Soil and topography characteristics: Sprinkler irrigation water method can be applied safely in soils with all kinds of structures from the soils with light structures and high water intake rates (with low usable water holding capacity) to soils with heavy structure and low water intake rates (with high usable water holding capacity), in deep soils, in shallow soils where impermeable layer or underground water is close, in low or high slopes and wavy topographies. However, the system should be arranged according to the topographic conditions of the land to be irrigated. Sprinkler irrigation method can also be used for the application of irrigation water for the reclamation of the saline soils.

Plant characteristics: In principle, sprinkler irrigation is not used to irrigate plants sensitive to diseases resulting from soaking the fruits and leaves. It can be used in irrigating all field crops except beans. Generally, vegetables, the leaves of which are eaten, can be irrigated with sprinkler method.

Vegetables, the fruits of which are eaten, such as tomatoes, pepper, beans, strawberries etc., should not be irrigated by sprinkler method. Similarly, sprinkler method should not be applied on stocks in orchards and trees in the fruit gardens other than banana trees in a way to give water over the plant. Fruit trees can be irrigated by means of irrigation method by applying water under trees.

Water source characteristics: Any kind of water source can be used in the sprinkler irrigation method. However, when streams are used for that purpose, attention should be paid to prevent sediments and floating objects to form up in a way they can clog the sprinkler nozzles and accumulate in pipelines. In this case, it will be more accurate to rest the water received from the stream in pools and give it to the system after the sediments are settled and floating objects are stopped with sieves. This increases irrigation costs.

Irrigation waters classified as 1st class (C1) and 2nd class (C2) in terms of salinity (the water with electrical conductivity lower than 750 $\mu\text{mhos/cm}$) can be used safely in sprinkler irrigation. However, as it is specified in the previous section, salt that may be left on leaves when 3rd class (C3) irrigation waters are used can cause leaves to burn.

4.5.1. Elements of Sprinkler Irrigation System

Individual sprinkler irrigation systems are generally comprised of a pump unit, a main pipeline, lateral pipelines and sprinkler nozzles (Figure 4.10). The characteristics of these elements are explained below.

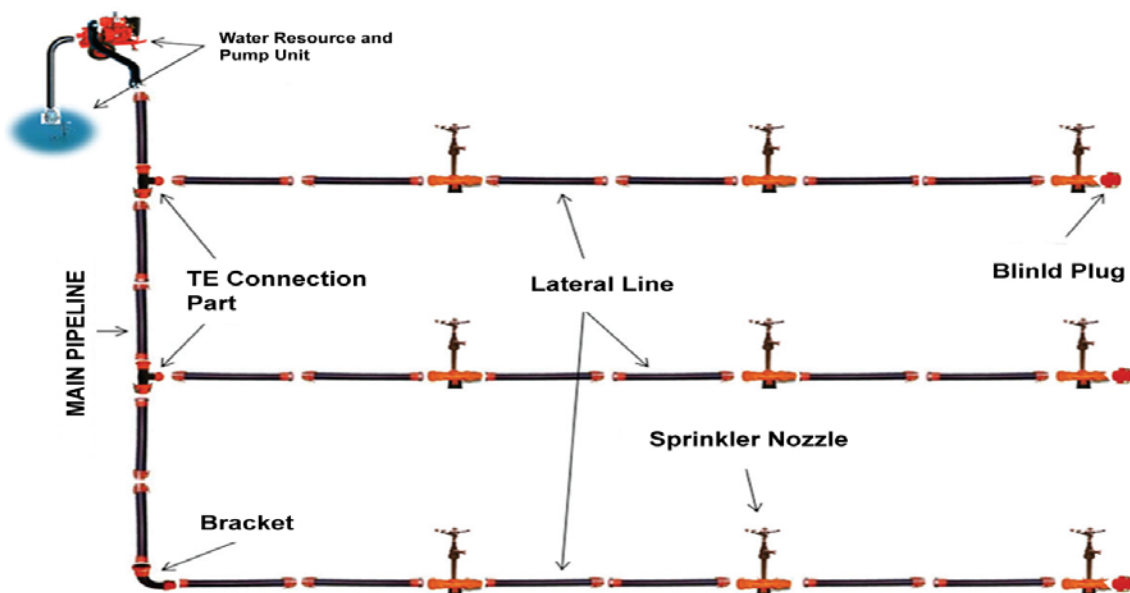
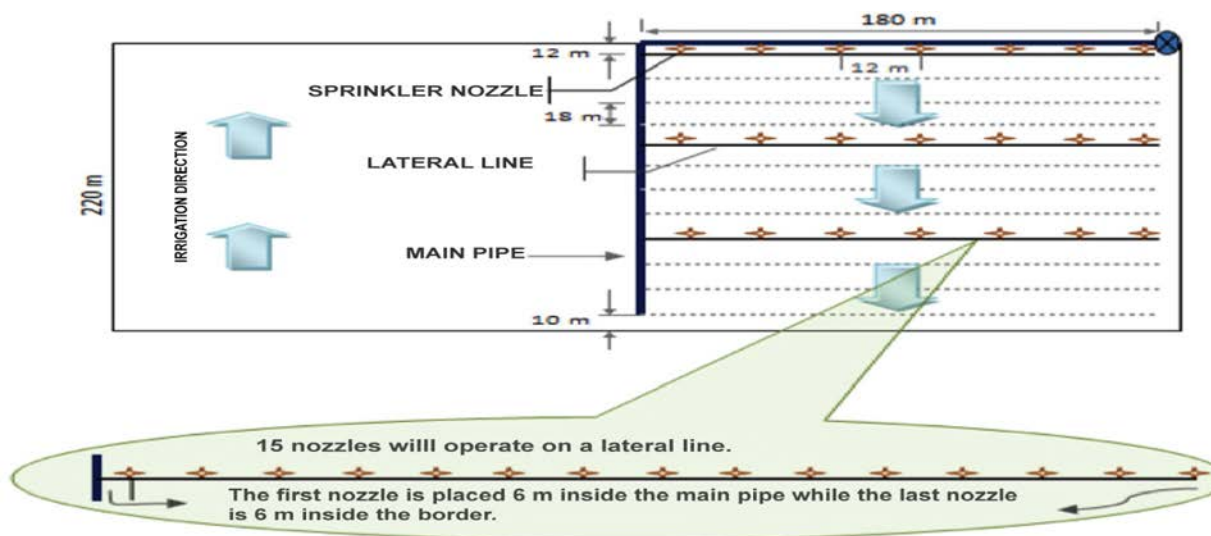

Figure 4.10 Elements of sprinkler irrigation system

- a. **Pump Unit;** Necessary operation pressure in sprinkler irrigation system is generally provided with the pump unit. The pump unit is comprised of the pump and the engine running the pump. In the cases when water sources such as streams, lakes, channels, caisson well etc. are used, in other words, when the pump dynamic absorption height is not so high, horizontal shaft centrifuge type pumps are used while deep well pumps or submersible pumps are used in deep wells. Electric motors are used to operate the pumps in the cases when power is supplied while internal combustion (generally diesel) motors are used when it is not possible to supply power. Pumps using electric motors are preferred since energy costs are low and it provides convenience in terms of operation and maintenance.

- b. **Main Pipeline;** The main pipeline delivers the irrigation water received from the sources to the lateral pipelines. It can be buried or laid on the surface. It is formed of rigid PVC or asbestos cement pipes with at least 10 atm operating pressure when it is buried while it is formed of aluminium or rigid PE pipes with at least 6 atm operating pressure when it is laid on the surface of the land. It is not desired for PVC pipes to be laid on the surface since they are sensitive to ultraviolet lights of the sun. In addition to that, even if it is rarely done, steel pipes can also be used in buried main pipelines.
- c. **Lateral Pipelines;** Lateral pipelines are pipelines on which sprinkler nozzles are placed. They are laid on the surface of the soil in portable or semi-fixed sprinkler irrigation systems and are formed of aluminium or rigid PE pipes with at least 6 atm operating pressure. In fixed sprinkler irrigation systems, on the other hand, lateral pipelines are generally buried. In this case, rigid PVC pipes with at least 10 atm operating pressure are used. However, only when pipes with very small diameters are necessary in fixed sprinkler irrigation systems established to irrigate grass areas in parks and gardens (lower than 63mm outer diameter), flexible (coil type) PE pipes can be used instead of rigid PVC pipes with adhered spigot for laying convenience.

When main pipeline and lateral pipelines are laid on the soil in sprinkler irrigation systems, special sprinkler gaskets, which can quickly flush the water inside the pipe when the pressure rises, can be used in the connection points. The gaskets in both buried main pipelines and the lateral pipelines should be impermeable in any case. In addition to that, the pipelines include connection elements such as pump connection, brackets, cross T pieces (+ piece), reduction piece, riser pipe, connectors with raisers (abot) and blind plugs. Also, pressure regulator with which pressure is controlled, water meters or flow meters with which water volume or flow rate is measured, manometers with which pressure is measured and valves with which water was checked are placed on pipelines.



- d. **Sprinkler Nozzles;** The most important elements of sprinkler irrigation systems which should be chosen with care are sprinkler nozzles. Sprinkler nozzles are placed on lateral pipelines; they receive the irrigation water from the pipeline, spray it under pressure and give it to the atmosphere. Spraying procedure is made by disintegrating water by means of nozzle.

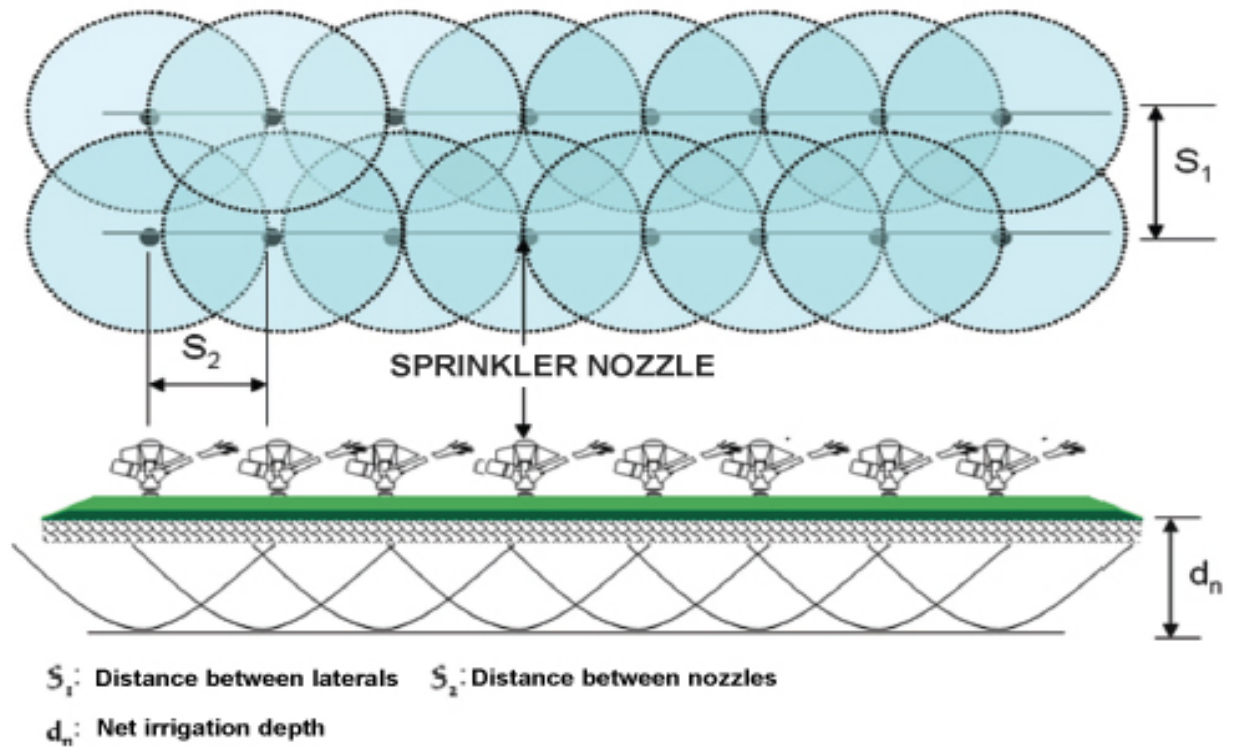

SOAKING AREA

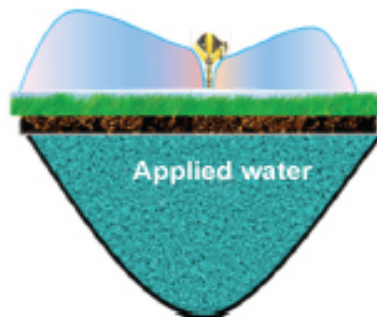

WATER DISTRIBUTION CURVE



Operating pressure: Operating pressure is the pressure desired in the output of the nozzle in sprinkler irrigation systems.

Classification of nozzles: Sprinkler nozzles are classified in Figure 3.2 and the types of nozzles are described below.

Fixed (spray) sprinkler nozzles: These are sprinkler nozzles which do not rotate around themselves and they may have 3 atm operating pressure at most. Nozzle diameters are around 1.0 mm. Their area of use is limited and they are generally used in increasing the relative humidity of the environment in plant growing in greenhouses, irrigating grass areas in very narrow strips, in irrigating fruit trees with micro sprinkler irrigation under trees and in lateral systems carried with machines over plants.

Rotating sprinkler nozzles: These nozzles rotate around their own axes. They are commonly used and their operating pressure and nozzle diameters change between wide ranges. They can be with one or double two nozzles.

The section of a typical rotating sprinkler nozzle is given in Figure 4.11 and the elements comprising the nozzle are written next to the figure. The rotation of the nozzle is ensured by the water beam emerging from the nozzle (7) under pressure and the crash lever (9). Connection gasket in the entrance of the nozzle (1) can

be with an internal pass as in the figure or an external pass. In the figure, another nozzle is mounted instead of blind plug (8) making the head part have two nozzles.

Slow rotating sprinkler nozzles: These are commonly used rotating type of sprinkler nozzles. Rotating speed changes between 0.8-1.2 rev/m (revolution/minute) Nozzle rotating speed is adjusted by stretching or loosening bear springs (5) and crash lever springs (10) as in figure 4.11. These are preferred since their soaking ranges are bigger than the ones rotating fast.

Fast rotating sprinkler nozzles: Their rotating speed is higher than 1.2 rev/m. The nozzles, which are mostly used in irrigation of grass areas and to which a certain soaking angle is given, are rotating type of nozzles.

Low-pressure sprinkler nozzles: These are nozzles with an operating pressure lover than 2 atm. Generally, their nozzle diameters do not exceed 3.5 mm while their soaking ranges do not exceed 16 m. They can be fixed or rotating types. They are used for irrigating fruit trees from below rather than irrigating field crops and vegetables. Small, low-pressure sprinkler irrigation nozzles placed under every tree (mini sprinklers) are used commonly for irrigating fruit trees from below. Nozzle diameters of the small sprinkler irrigation nozzles are 1.3 mm while their operating pressures are 1-2 atm and soaking ranges are 2-8 m. The irrigation method , in which such sprinkler nozzles are used, are included to the micro irrigation methods since it has a low operating pressure and the whole are is not soaked, and it is named as under-tree micro sprinkler irrigation method. This method will be explained in the next sections.

Medium-pressure sprinkler nozzles: These are nozzles with a operating pressure between 2-4 atm. Their nozzle diameters range between 3.5-6.0 mm while their soaking ranges differ between 20-36m and their nozzle space range between 12-24 m. They are generally the rotating type with one or two nozzles. They are mostly used in irrigating field crops and vegetables.

High-pressure sprinkler nozzles: These are nozzles with a operating pressure between 4-6 atm. Their nozzle diameters range between 6.0-12.0 mm while their soaking ranges differ between 20-60 m and their nozzle space range between 18-36 m. They are generally the rotating type double nozzles. They are mostly used in irrigating field crops and vegetables.

Very high-pressure sprinkler nozzles: These are nozzles with an operating pressure higher than 6 atm. Their nozzle diameters range between 12.0-32.0 mm while their soaking ranges differ between 60-180 m and their nozzle space range between 30-20 m. They are generally the rotating type double nozzles. The diameter of the small nozzle is mostly between 6.0-12.0 mm. This kind of nozzles is also named jet type sprinkler nozzles. (Figure 3.4). It is used in large agricultural enterprises and for irrigating field crops.

Field type sprinkler nozzles: Water spraying angles (the angle made by the nozzle axis with the horizontal plane) is 30°-33°. The highest soaking range is obtained with this angle. This is used in irrigating plants from above.

Garden type sprinkler nozzles: Their water spraying angles are 10°-12°. It is used in irrigation of fruit trees from below in a way to soak the whole area. Generally, the lateral pipes are laid in both sets of trees and the sprinkler nozzles are laid in way that they are located in the middle of 4 trees. Lateral pipelines are moved from one location to another. The angle is set low to not to soak the branches and leaves of the trees. Water spraying angle with the micro sprinkler irrigation method used under trees may be much lower and even at a reverse angle

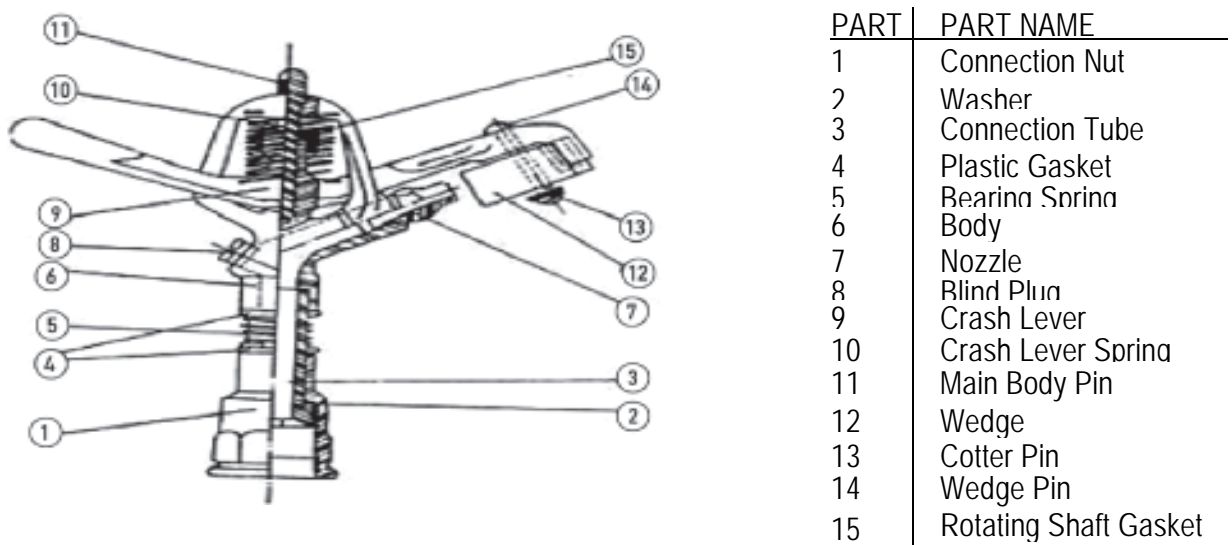
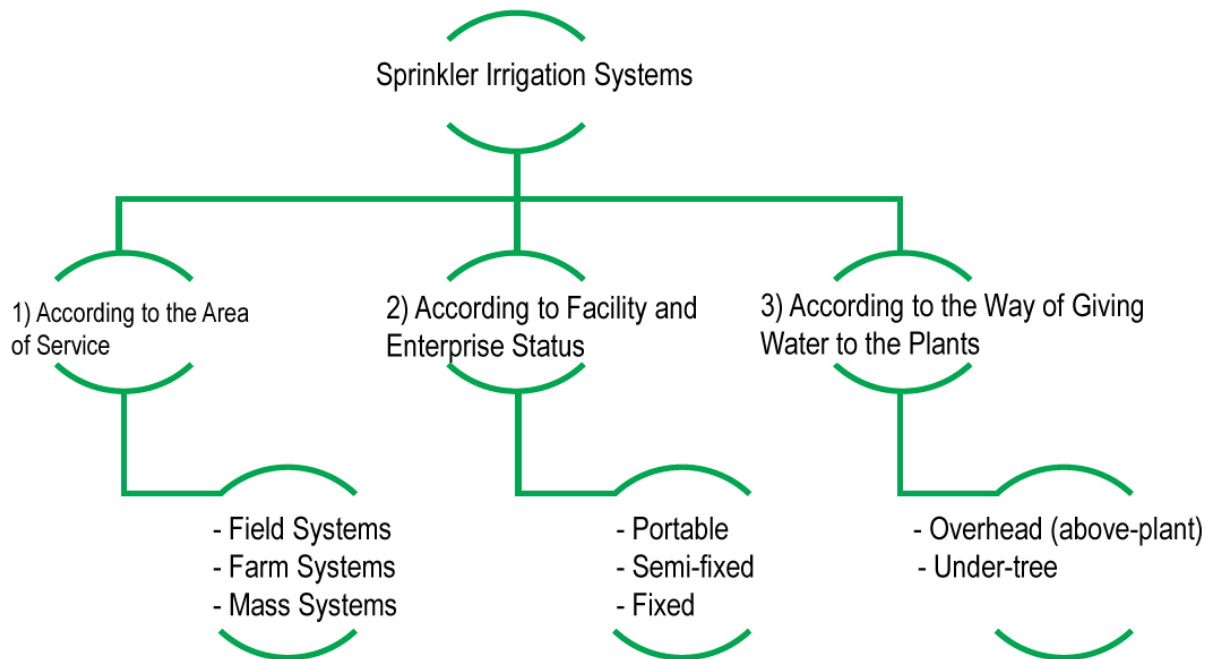

Figure 4.7 7. Rotating type sprinkler nozzle

4.5.2 Types of Sprinkler Irrigation Systems

Sprinkler irrigation nozzle systems can be classified according to the area, where the service will be provided, the situation of the facility and the enterprise and the manner of giving water to the plant.



a. **Systems According to the Area of Service**

Field systems: Although the irrigation method applied in the agricultural enterprise is different (generally surface irrigation methods are used), the sprinkler irrigation systems established to give germination and tail water to the plants, to make support irrigation or to irrigate a special plant in crop rotation are named field type systems. They are generally portable systems



Farm systems: These are the systems established when sprinkler irrigation methods are used in an agricultural enterprise. These systems include all the sprinkler irrigation system elements and all enterprise and control tools needed for effective irrigation. Generally, they can be

moved in small agricultural enterprises and they are established in a semi-fixed way in medium sized or large agricultural enterprises. Portable systems, in which laterals are moved by machines, can also be used in large agricultural enterprises.

Mass systems: These are the systems providing service to large areas containing many agricultural enterprises. A hydrant, from which agricultural enterprises can take water, is placed in every agricultural enterprise. A farm system is established in every agricultural enterprise. Hydrants in the area are appropriately connected to the water source with a water distribution network

b. Systems According to Facility and Enterprise Status

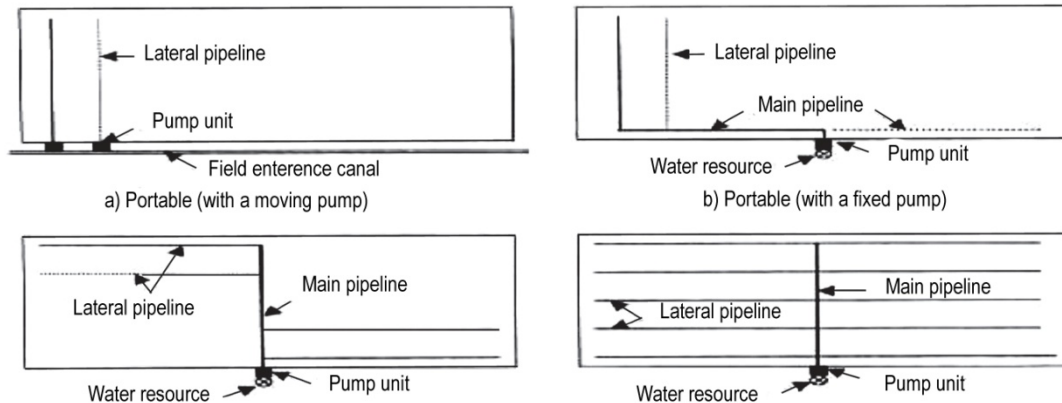

Portable systems: Portable systems are the systems in which both main pipeline and lateral pipelines are moved to another location after irrigation is completed at a location. Pumps can be portable (Figure 3.6 a) or fixed. (Figure 3.6 b). Main and lateral pipelines are laid on the soil surface in these systems. This type of systems is generally used in small agricultural enterprises. Main and lateral pipelines are moved from one location to another by hand. System's cost per unit area is low and labour for water is higher than the cost.

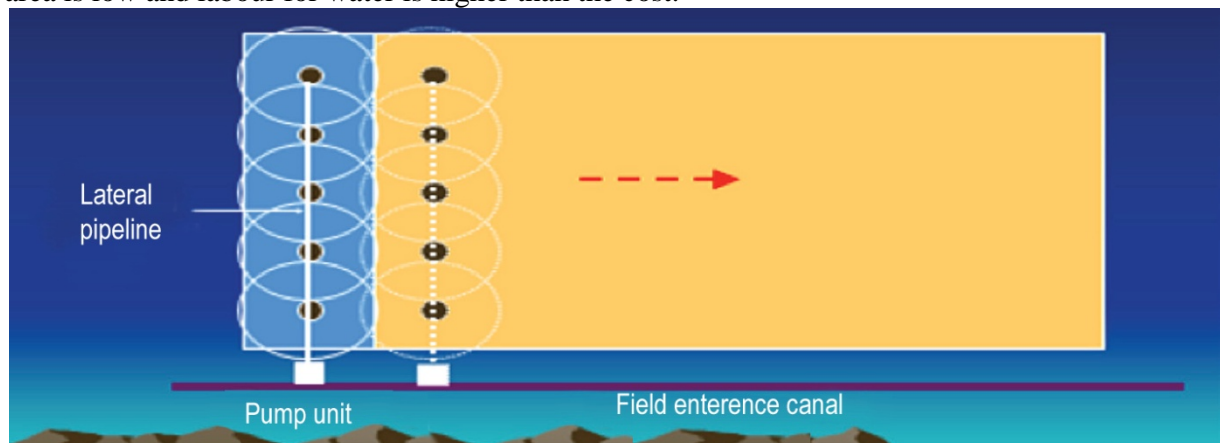

Semi-fixed systems: Main pipeline is fixed and mostly buried in semi-fixed systems. Lateral pipeline are laid on the surface of the land and they are moved to another location after irrigation is complete at a location (Figure 3.6.c). In practice, on the other hand, this is the system which is most commonly used for irrigating field crops and vegetables in relatively large agricultural enterprises. When compared to the portable systems, system costs per unit area are higher in the cases when laterals are moved by hand; however, irrigation labour is lower than the cost.

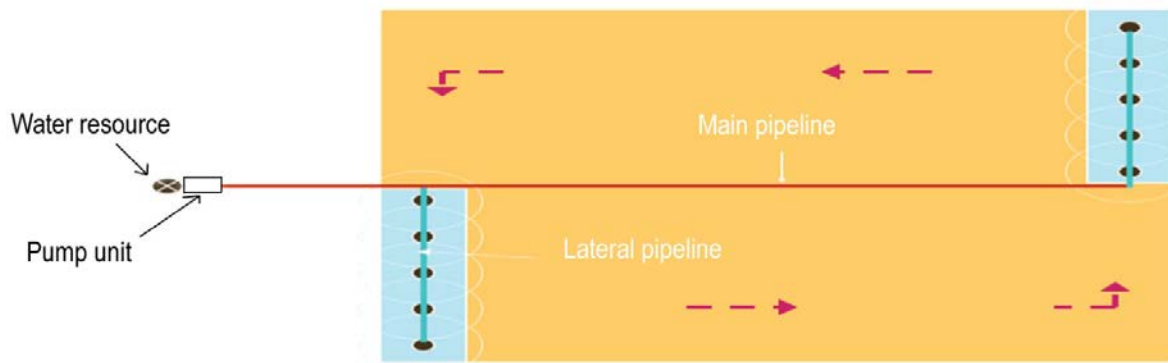

Fixed systems: All the elements of the system are fixed in terms of position (Figure 3.6 d). Main pipeline and the lateral pipelines are generally buried. Sprinkler nozzles are taken out to the surface of the water with a riser pipe. Establishment costs per unit area are very high while the irrigation labour costs are quite low. Generally, they are used to irrigate grass areas in parks and gardens rather than irrigating field crops and vegetables. In addition to that, micro irrigation systems under trees containing small sprinkler nozzles, which are used to irrigate fruit trees, are fixed systems and the lateral pipelines are laid on the surface of the soil in these systems. Together with the sprinkler nozzles, lateral pipelines are removed and stored at the end of the irrigation season.

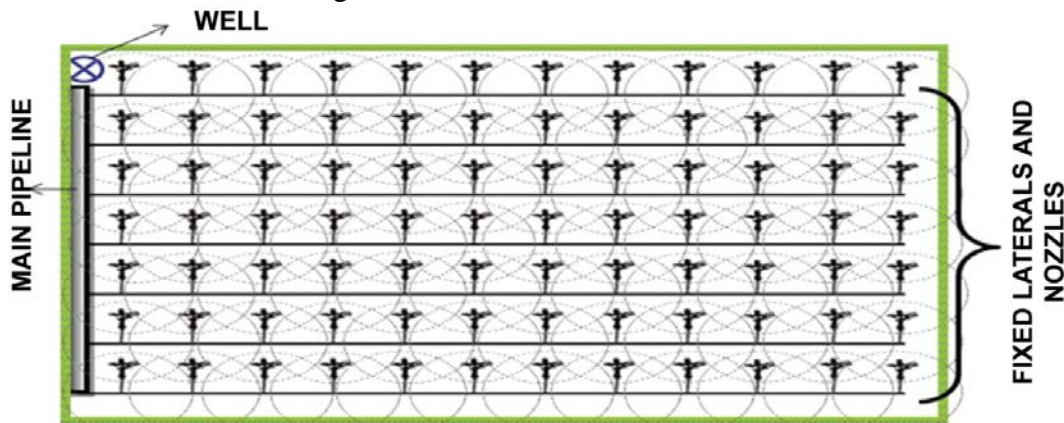

c. Systems carried by machines

- Wheeled sprinkler irrigation system
- Drummed sprinkler irrigation system
- Centre-pivot sprinkler irrigation system
- Linear moving sprinkler irrigation system

Lateral pipelines may also be moved by machines in portable or semi-fixed systems in large agricultural enterprises. As the years pass by, these systems developed to ensure that large agricultural lands are irrigated in the most economic way with high performance procured acceptance for them with irrigating many plants in different lands and climatic conditions. Centre pivot irrigation machines are formed of towers the heights of which range from 30 to 65 meters.

Areas as large as thousands of acres can be automatically irrigated without the touch of a hand by using centre pivot irrigation systems. Centre pivots reach a radius between 50 meters and 1100 metres (A single machine can make irrigation approximately up to 3800 decares).



By means of centre pivot irrigation systems, irrigation can be made using 35-50% less water than other surface irrigation systems. Using these nozzles, surface irrigation systems, different sprinkler irrigation shooting designs and irrigation distances can be chosen according to the types of the plans. Also, it is possible to irrigate a larger area with an extra pump and sprinkle that can be added to the end of the system. Pipes used in centre pivot and linear irrigation systems are steel or aluminium pipes galvanized with hot-dipping process and they can optionally be covered with PVC on the inside to increase their resistance against chemicals.

Using centre pivot - linear (linear pivot and drummed) irrigation systems;

- Cotton, Corn, Wheat,
- Lentil, Barley, Alfalfa,
- Sugar Beet,
- Shrub Fruit Trees and Citrus Trees,
- Melons, Watermelons,
- All fodder plants,
- Onions, Potatoes
- Legumes

and many similar plants can be irrigated in the most ideal conditions.



d. Systems According to the Way of Giving Water to Plants

Sprinkler irrigation systems above plants; the water is given from above the field crops and vegetables. Irrigation is made by spraying the water with an angle of 300° - 330° degrees and arranging its height according to the height of the plant.

Sprinkler irrigation systems under trees; These are the irrigation systems using pressurised mini-jet spray sprinkler (angled or fixed) with low flow rate for irrigating especially fruit trees

4.6. DRIP IRRIGATION METHOD

The main principle in the drip irrigation method is, without creating a tension that can arise from a lack of moisture in the plant, to give small amounts of irrigation water in frequent spacings every time to only the surrounding area in which the plant roots develop. With this method, irrigation can sometimes be made daily and in fact more than once each day.

In the drip irrigation method, purified water is conveyed through a pressurised piping system all the way to the drippers positioned near the plants and are distributed through the drippers under low pressure to the soil surface. From here, the water seeps into the soil through infiltration and the soil volume in which plant roots develop is wetted with the influence of gravity and capillary force. In other words, in this method usually the entire area is not wetted. A wet strip is obtained throughout the line of plants and a dry area that has not been wetted is left between the lines of plants. This way, existing irrigation water is utilized at the utmost level.

The drip irrigation method is in the format of a fixed system. System elements remain in the same position throughout the irrigation season. However, at the end of the irrigation season, some elements are removed from the land.



4.6.1. Components of the Drip Irrigation System

A drip irrigation system consists of a pump unit, control unit, main pipeline, manifold pipelines and drippers (Figure 4.13).

Water Source: In the drip irrigation method, all kinds of water sources are utilized. But, the water must not entail too much sand, sediments and suspended substances. Moreover, waters that entail large amounts of calcium and magnesium compounds and iron compounds are also not appropriate for the drip irrigation method.

Pump Unit: In conditions where the water source is not high enough, the necessary operating pressure is provided through the pump unit. Depending on the type of the water source, either a centrifuge, deep well pump or a submersible pump can be used. Operating the pump with an electric motor is preferred.

Control Unit: In drip irrigation, the water must be conveyed to the system after filtering it thoroughly. Furthermore, the pressure and amount of the irrigation water to be supplied to the system can also be checked in the control unit and the plant nutrients are mixed into the irrigation water.

In the control unit; a hydrocyclone, sand-gravel filter tank, fertilizer tank, mesh-filter, pressure regulator, water measurement instruments, manometers and valves are found (Figure 4.13).

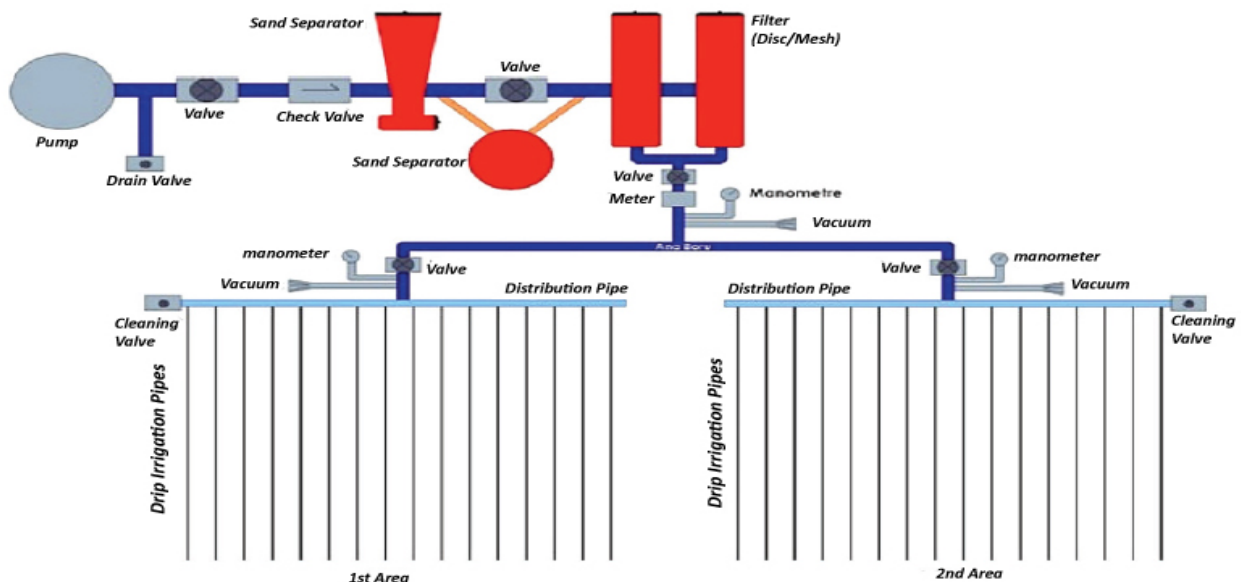

Hydrocyclone is the instrument in which sand particles, which can be found in water, are kept before entering the system. The cross-section of the hydrocyclone and the water's movement in the hydrocyclone is found in figure 4.14. As can be seen from the figure, water enters from the top part of the hydrocyclone towards the boundary and flows downwards throughout the boundary. Then, the water rises from the middle to the top and sand particles, since they are heavy, remain at the base. The water clarified from the sand is conveyed to the system from over the hydrocyclone. The sand gathered at the bottom is cleaned in spacings.

Sediments and suspended substances that can be found in the irrigation water are kept in the sand-gravel filter tank. The cross-section of a typical sand-gravel filter tank is given in figure 4.15. The water enters the tank from the top; after passing through layers of sand and gravel, it exits from the bottom of the tank. Meanwhile, sediments and suspended substances are usually stored in the upper portion. A perforated pipe whose outer side is wrapped by a mesh filter exists. The purpose here is to prevent sand from flowing out of the tank together with water. A backwash pipe is also found in a sand-gravel filter tank which allows water to enter from the bottom and to exit from the

valve at the top. By means of this pipe, sediments and suspended substances gathering in the upper portion of the tank are washed and cleaned from time to time.

In drip irrigation systems, plant nutrients are applied by mixing them into the irrigation water. For this reason, liquid fertilizer is used. The amount of liquid fertilizer, which is measured according to the size of the land to be irrigated, is placed into the fertilizer tank in the control unit. The fertilizer tank is connected to the main pipe through hoses that have valves on them from two points. One is for water inflow to the fertilizer tank, while the other is for water outflow. In order to create a pressure difference between the two points mentioned above, another valve is also placed on the main pipe. When fertilizer is to be applied, the valve on the main pipe is partially closed and inflow and outflow valves to the fertilizer tank are opened. This way, some of the water in the main pipe enters the fertilizer tank, mixes with liquid fertilizer and returns again to the main pipe. (Figure 4.17)

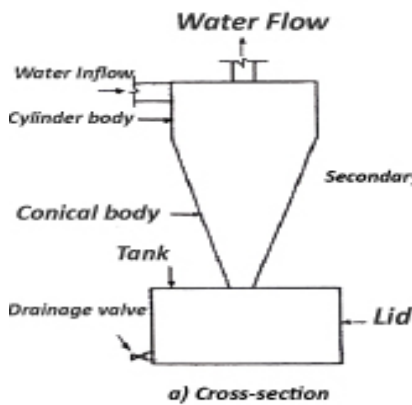

Şekil 4.14. Hydrocyclone

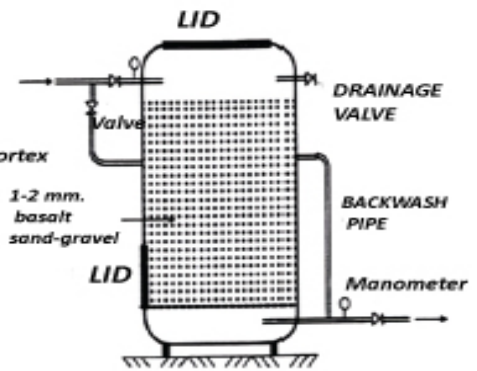
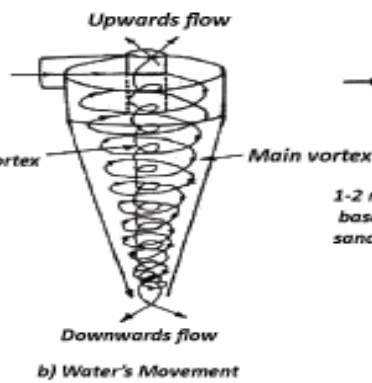

Şekil 4.15. Sand-gravel filter

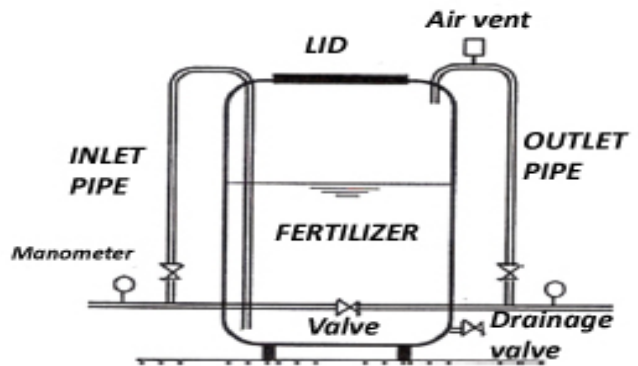

Şekil 4.17 Fertilizer tank and its cross-section

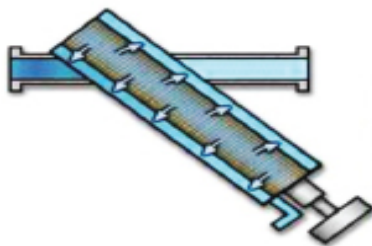

Şekil 4.18 Cross-section of a mesh filter

After the mesh filter, in order to ensure that water is conveyed to the pipeline under a stable pressure, a pressure regulator is placed. Pressure regulators can also sometimes be placed in the entrance of the manifold pipeline.

The inlet and outlet of the sand-gravel filter tank and the pressure at the entrance of the mesh filter must also be measured in the control unit. For this purpose, a three-way manometer is utilized. Therefore, the clogging degree of the filter is determined from the differences in pressure and the filters are cleaned when necessary.

Main pipeline: Transmits the water from the source to the manifold pipelines. Usually they are buried and are formed from hard PVC or PE pipes. In small systems, the main pipeline (hard PE) can be installed over the soil's surface.

Manifold pipeline: Transmits the water from the main pipeline to laterals. In case of the laterals directly being connected to the main pipeline, it is mandatory to position a valve at the beginning of each lateral so as to monitor water inflow. This not only increases the cost of the system in significant degrees, but also makes the operation of the system difficult. Instead of this, a specific number of lateral pipelines are connected to the manifold pipeline and the connection of the manifold with the main pipeline is enabled through a valve. All laterals connected to the manifold pipeline constitute an operation unit. When the valve at the beginning of the manifold is opened, water is distributed at the same time to all laterals within the operation unit. Just as in the main pipelines, manifold pipelines are also generally buried and are formed by hard PVC pipes. In small systems, manifold pipelines are sometimes laid over the soil surface and PE pipes are used in this situation. Manifold pipelines must be installed parallel to contour lines (flat) or sloping downwards. Installing on an upwards slope must absolutely be avoided. Just as these lines can be vertical to the main pipeline, they can also be parallel.

Lateral pipelines: Consists of pipes on which drippers have been placed. They are laid over the soil surface and for this purpose, soft PE pipes are used. Usually one lateral is installed for each line of plant. Sometimes two laterals for every two plant lines or one lateral for every two plant lines can be placed. As in manifold pipelines, lateral pipelines must also be installed parallel to contour lines (flat) or sloping downwards and installing them on an upwards slope must be avoided.



Drippers: These are the most important components that have to be selected with caution. After the pressurized water in the lateral pipes reaches the dripper, while advancing throughout the flow line in the dripper, the water's energy is broken down to a great extent by friction. As a result, the water emerges from the dripper in drops with very low flow rate and infiltrates into the soil.

In general, drippers are produced in two types as fitted on lateral (on-line) and fitted lengthwise to the lateral (in-line). (Figure 4.19) In drippers fitted on the lateral, the entrance of the dripper is inside the lateral pipe and its body is outside the pipe. These types of drippers are orifice entry and usually have a short flow line. The energy of the water is broken at the orifice at the entrance and throughout the flow line. In drippers that are fitted lengthwise to the lateral, either the lateral pipe is connected to the two ends of the dripper or the drippers are stationed inside the lateral pipe in fixed spacings and lengthwise. The flow line is usually long. The water enters the dripper from the lateral or its boundary, its energy is broken down throughout long flow line and emerges out of the lateral pipe. In practice, drippers are made from PVC, PE and ABC (Acrylonitrile Butadiene Styrene).

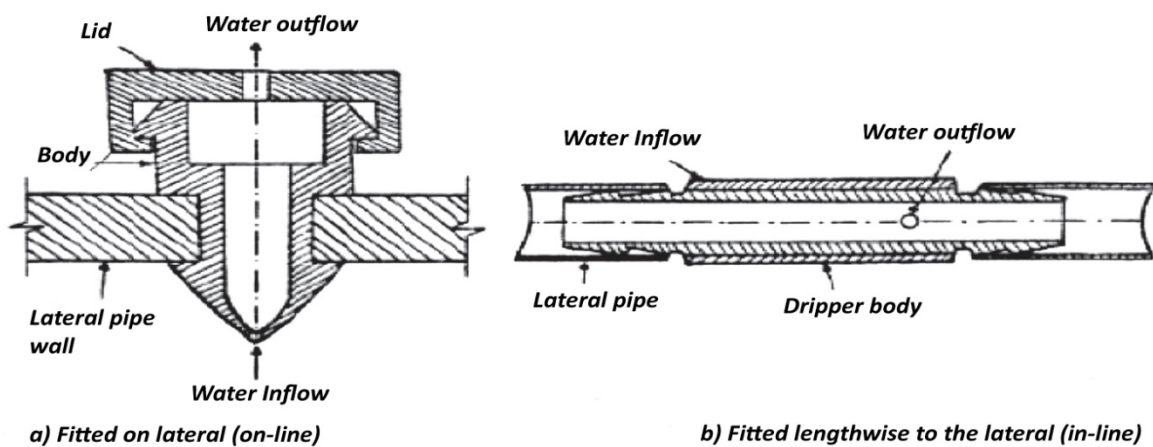

Figure 4.19 Cross-sections of drippers fitted on lateral and lengthwise to the lateral

A relationship as given below exists between the operating pressure and dripper flow rate.

$$q = K_d - h^x$$

In this equation;

- q = dripper flow rate, L/h
- Kd = coefficient depending on the production type of the dripper,
- h = operating pressure (the desired pressure at the entrance of the dripper), m
- x = coefficient in the dripper depending on the flow regime.

The relationship provided in this equation between the dripper pressure and flow rate is determined in laboratory experiments by measuring dripper flow rates at different pressures. Apart from this, drippers having their own pressure regulators are also produced. In these types of drippers, even though the operating pressure changes, the flow rate remains fixed. The manufacturer establishments are obliged to provide the charts or graphics showing dripper flow rates at different operating pressures to the designers and the operators. (Figure 4.20) In order to prevent the accumulation of chemical substances throughout the flow line in the dripper, the operating pressure should not be chosen less than 1 atm unless required. As for systems where the operating pressure is generated through the pump unit, choosing the pressure to be higher than 1 atm will increase energy costs. In other words, in systems where the pressure is generated through the pump unit, the pressure is fixed at a certain point and this value is 1 atm.

As to dripper flow rates, it must be low in heavy textured soil where water intake rate is low and must be high in light textured soil where water intake rate is high. In practice, it is recommended that the dripper flow rate is chosen between 1.2-4 L/h in heavy textured soil, between 4-6 L/h in mild textured soil and between 6-16 L/h in light textured soil.

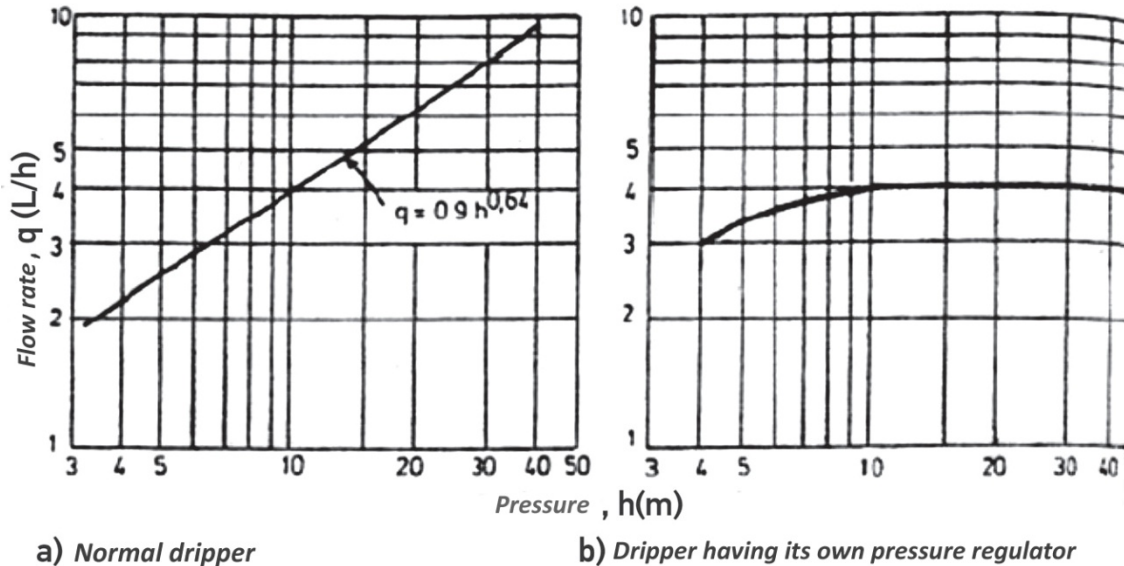

Figure 4.20. Graphics of the relationship between dripper operating pressure-flow rate

4.6.2. Wetting Patterns and Lateral Arrangement Styles in Drip Irrigation Method

In the drip irrigation method, a dripper usually wets a circular area (Figure 4.21). The cross-section of the wetting area resembles an onion bulb (Figure 4.21). Throughout the lateral, drippers are placed at spacings that make up 80% of the wetting diameter. This way, a wet strip is created throughout the lateral. But, especially in the irrigation of plants that have wide spacings of lining, a dry area remains between the laterals that have not been wetted. (Figure 4.22)

The dripper spacing is a function of the total water intake rate and dripper flow rate. This is calculated with the following equation.

$$S_d = 0.9 \sqrt{\frac{q}{I}}$$

In this equation;

- S_d = Dripper spacing, m
- q = Dripper flow rate, L/h
- I = Water intake rate of soil, mm/h.

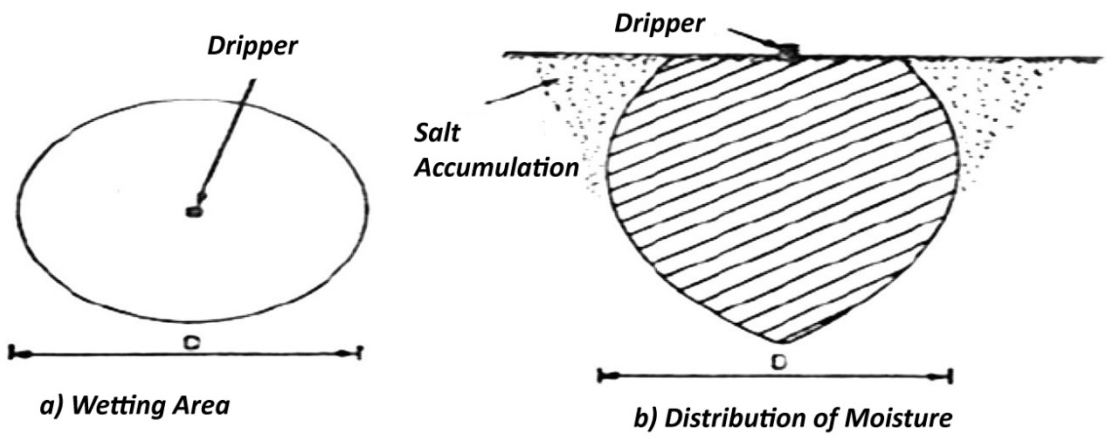

Figure 4.21. The area wetted by a dripper and the distribution of moisture in soil

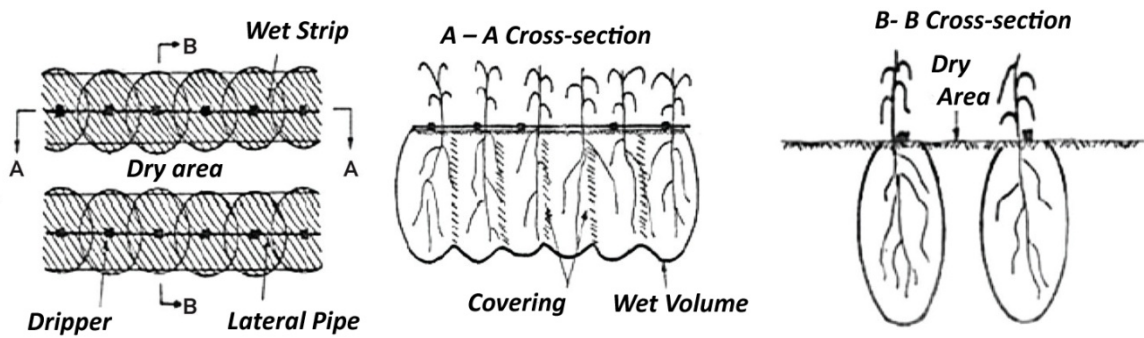

Figure 4.22. The area wetted throughout the lateral.

In field crops and vegetables, if the line of plant spacing is greater than the dripper spacing, one lateral pipeline is installed for every two lines of plants. In other words, the lateral spacing equals the line of plant spacing. (Figure 4.23)

In this situation, the percentage of the wetted area is found with the following equation;

$$P = 100 \frac{S_d}{S_l}$$

In this equation;

- P = Wetted area percentage, %
- S_d = Dripper spacing, m
- S_l = Lateral spacing, m.

If the dripper spacing is greater than the plant line spacing, but smaller than twice the plant line spacing, the lateral pipelines are installed in the middle of two lines of plants and two lines of plants are irrigated with one lateral pipeline. In this situation, the lateral spacing is equal to twice the plant line spacing (Figure 4). The wetted area percentage is calculated with the equation provided above.

Concerning plants that are frequently cultivated or planted, the laterals are installed in such a way that the lateral spacing equals the dripper spacing and the entire area is wetted.

When concerning vines, young fruit trees or fruit shrubs, usually one lateral pipeline is installed for each line of trees. The drippers are placed throughout the lateral in spacings determined from the following formula. This way, the top of the line of trees is entirely wetted without any dry area remaining. The dry area remains between the lines of trees. The wetted area percentage is found with the equation given earlier.

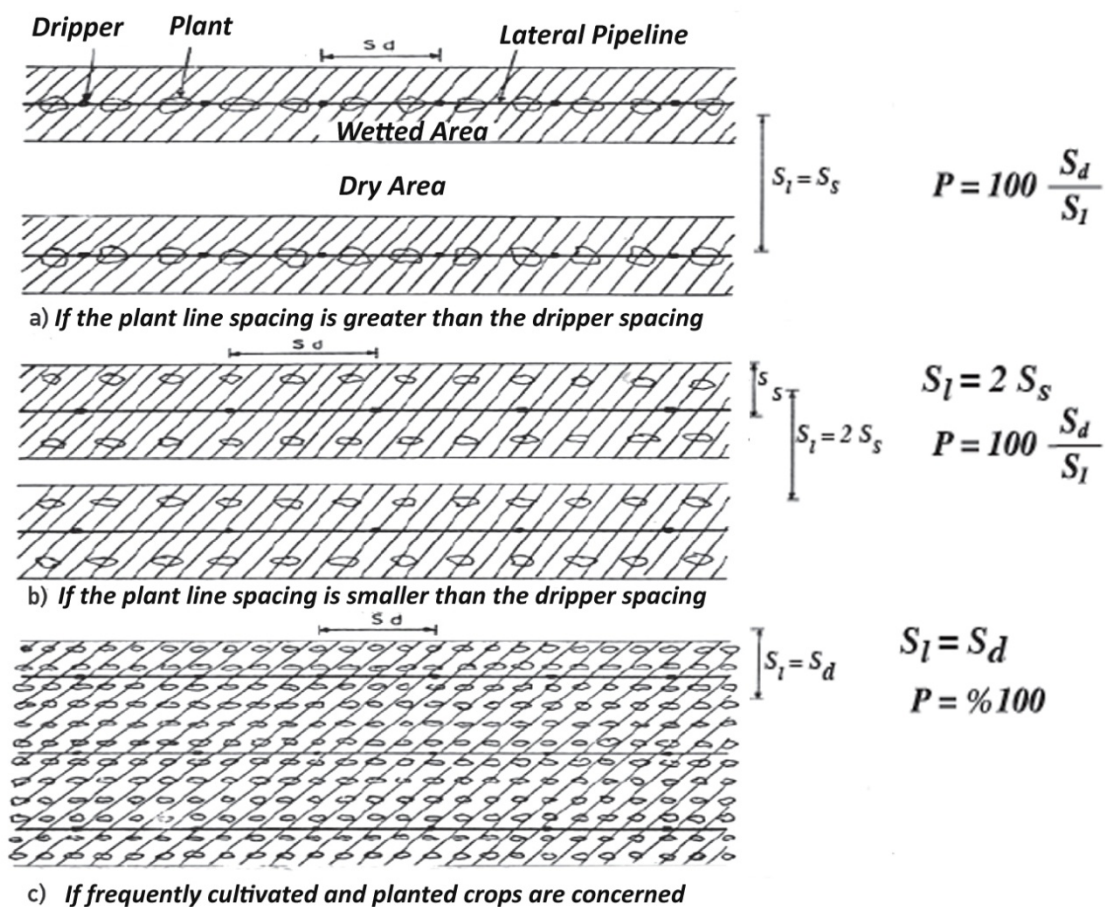

Figure 4.23. Lateral arrangement styles in field crops and vegetables

Concerning mature fruit trees, usually two lateral pipelines are installed for every line of trees. In each line, the laterals are placed on two sides of the trees in a way that the lateral spacing equals the dripper spacing. Therefore, moisture is distributed uniformly along the line of trees, but a wider area of wet strip is obtained. In this situation, the wetted area percentage is determined with the following equation;

$$P = 100 \frac{2S_d}{S_l}$$

In this equation;

- P = Wetted area percentage, %
- S_d = Dripper spacing, m
- S_l = Lateral spacing, m.

For mature fruit trees that are planted in wide spacings, by installing one lateral for each line of trees, one multiple output dripper can be placed for each tree. (Figure 4.24) The number of dripper outputs can be 4, 6 or 8. By mounting very small scale capillary pipes at every output, water outflow points are placed around the tree trunk in equal spacings. This way, a circular wet area will be formed at the bottom of each tree. Just as can be found in between the lines of trees, a dry area that has not been wetted can also remain between the trees situated on the line. In this situation, the wetted area percentage is calculated with the following equation;

$$P = 100 \frac{nS_\xi^2}{S_a S_s}$$

In this equation;

- P = Wetted area percentage, %
- n = Number of dripper outputs per tree, piece
- S_ξ = Water outlet point spacing, m
- S_a = Tree spacing on the line, m
- S_s = Tree line spacing, m.

For mature fruit trees whose planting spacings are wide, another lateral arrangement style is to install one lateral pipeline for each tree lining and to place a smaller scale circular pipeline around the trunk of the tree. The drippers are found on this pipeline. This is called a cluster arrangement style. (Figure 4.24 d) This way, a circular area is wetted at the bottom of every tree. A dry area can remain between the trees on the line and between the lines of trees.

The wetted area percentage in the cluster arrangement style is calculated with the following equation;

$$P = 100 \frac{nS_d^2}{S_a S_s}$$

In this equation;

- P = Wetted area percentage, %
- n = Number of dripper outputs per tree, piece
- S_d = Dripper spacing
- S_a = Tree spacing on the line, m
- S_s = Tree line spacing, m.

In the areas in which drip irrigation method is applied, the wetted area percentage must at least be 30% (P > %30). It is not permitted to fall below this value. Or else, the problem of the plant root area not being wetted entirely can be encountered. This issue is especially important for fruit trees.

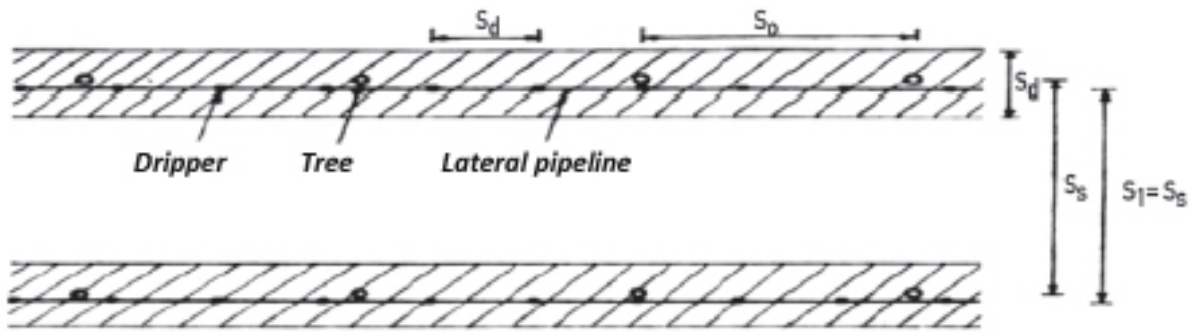

a) Single lateral arrangement style for each tree line

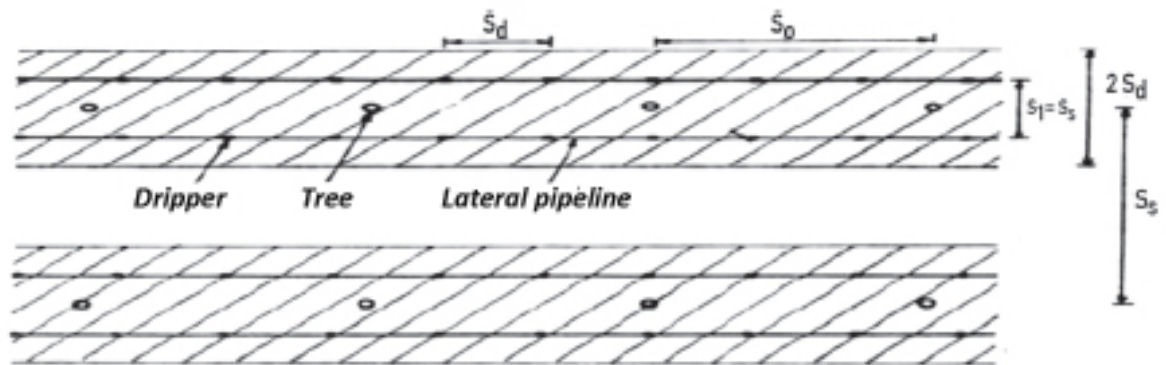

b) Two lateral arrangement styles for each tree line

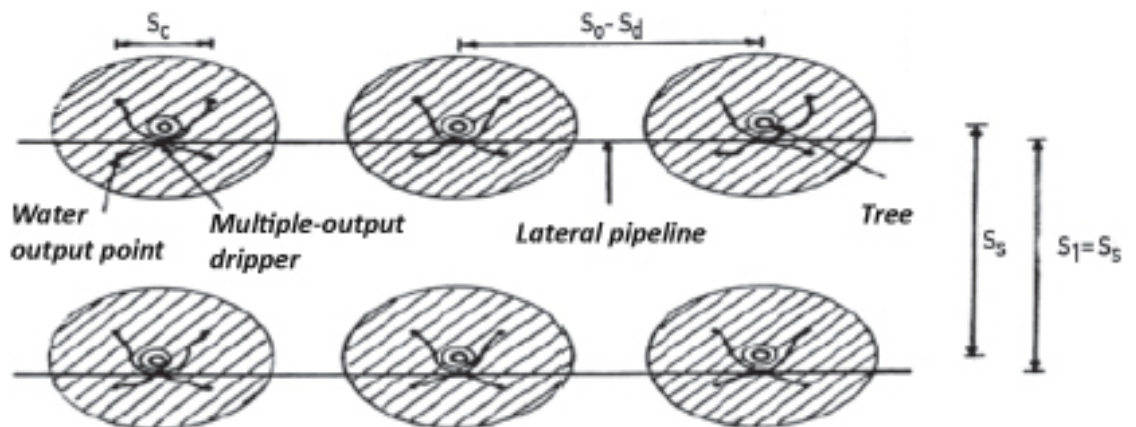

c) Multi-purpose dripper containing lateral arrangement style

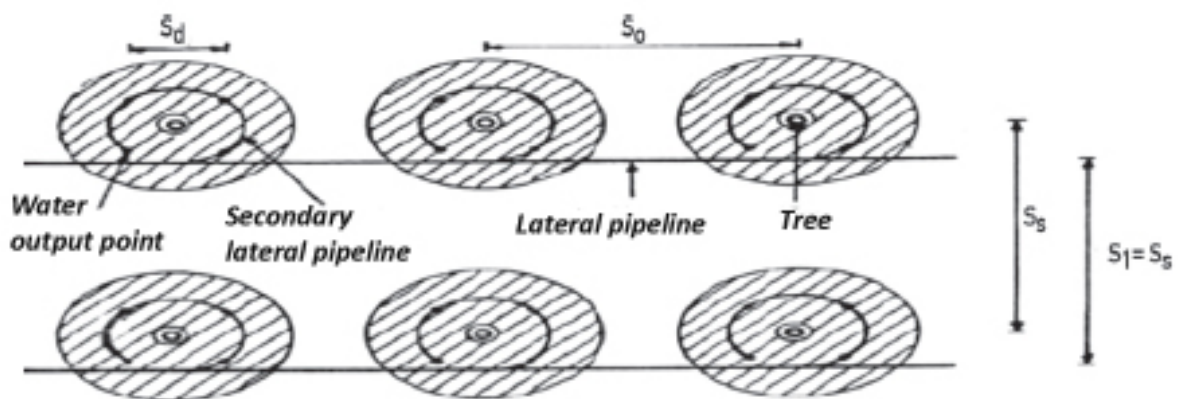

a) Cluster arrangement style

4.6.3. Advantages of the Drip Irrigation Method and the Factors Limiting Its Application

The advantages of the drip irrigation method compared to other irrigation methods are as follows:

- Since only a certain part of the land is wetted, irrigation water need is reduced and a larger area can be irrigated under limited water resource conditions.
- Since the wetted soil surface is shadowed by the plant, evaporation from the soil surface, thus, consumptive water use is less.
- Since a continuous and low tension moisture medium is provided at the plant root zone, the plant takes the water from the soil without spending much energy and this is one of the most important factors providing the increase of productivity.
- Plant nutrients are given only to the medium where plant roots develop when the plant needs and the fertiliser is made use of at the optimum level.
- The salts in the soil are forced to the perimeter of the wet strip, ensuring a safe cultivation in salty soils.
- Irrigation water can be used at the amount desired and with the best control, water application efficiency is very high.
- It is easy to operate and the workmanship is at the minimum level.
- As the plant organs above the ground are not wetted, development of plant diseases are hindered; control of foreign weeds is easier.
- As there are dry areas between the plant rows, some agricultural works may be carried out even during irrigation.
- It can be safely applied on high sloped, fluctuating, light or shallow soils as with the sprinkler system.
- As the operational pressure is lower compared to that of the sprinkler irrigation system, energy costs are low.

Besides the above mentioned advantages, there are some factors that limit the application of this method. These factors are listed below:

- The most important problem in the drip irrigation method is the clogging of the drippers. Mostly the cause of clogging is sand and silt particles, organic material development and accumulation of organics. Thus, the irrigation water must be filtered well in the control unit and the system must be washed with dilute acid at certain intervals.
- Even if the irrigation water is of high quality, it contains some amount of salt. In addition, the soil also contains salts. In drip irrigation, these salts are transported to the perimeter of the wet volume by the movement of water and accumulate there. In general, such salts are washed away to deeper layers by snow. However, in regions where the annual precipitate is below 300 mm this washing may be insufficient and it may be necessary to apply supportive sprinkling or surface irrigation methods to wash away the accumulated salts to move under the root zone.
- In drip irrigation, initial installation costs are rather high. However, especially when the water source is limited and plants with high economic value are being cultivated, drip irrigation is generally economic since a larger area can be irrigated and more product is obtained per unit area.

4.6.4. Amount of Irrigation Water Applied at Every Irrigation, Irrigation Interval and Irrigation Duration

In drip irrigation method, the irrigation water is applied at frequent intervals, with a small amount of water at each time. The maximum net irrigation water to be applied at each irrigation is found using the following equations; when the usable water holding capacity is in percentage:

$$dn = \frac{(TK-SN)R_y}{100} Y_t D$$

and when the usable water holding capacity is in depth:

$$dn_{max} = d_k D Y R_y \frac{P}{100}$$

where

dn_{max} = Maximum net amount of irrigation water to be applied at each irrigation application, mm
 TK = Field capacity, %
 SN = Wilting point, %
 R_y = The part of the usable water holding capacity allowed to be consumed,
 Y_t = Density of soil, g/cm^3
 D = Soil depth to be wetted, mm
 P = Percentage of the area to be wetted, %
 dk = Usable water holding capacity, mm/m.

In drip irrigation method, in general, irrigation is started when 30% of the water holding capacity is consumed ($R_y = 0.30$). For plants that are relatively resistant to the lack of moisture in soil, this value may go up to about 40%. In addition, the value calculated using equation (4.19) or (4.20) gives the maximum applicable net amount of irrigation water. This value may be reduced by the designer or the operator. In other words, the net amount of irrigation water is determined so that $dn < dn_{max}$.

Since there are dry areas in drip irrigation method, evaporation from the soil surface is rather small. Thus, in this method, consumptive water use of the plant is lower compared to irrigation methods in which the land surface is completely wetted. In drip irrigation method, consumptive water use of the plant is calculated using the following formula:

$$T = ET \frac{P_s}{85}$$

where

T = Consumptive water use of the plant in drip irrigation method, mm/day
 ET = Consumptive water use calculated using conventional methods, mm/day
 P_s = Percentage of the area shadowed by the plant, %.

In drip irrigation method, the maximum irrigation interval that can be considered is found by the formula

$$SA_{max} = \frac{dn_{max}}{T}$$

where

SA_{max} = Maximum irrigation interval, day
 dn_{max} = Maximum net amount of irrigation water, mm
 T = Consumptive water use, mm/day

The operator or the designer may assume a lower value so that $SA < SA_{max}$.

The total amount of irrigation water to be applied at each irrigation is found by the equation

$$d_t = \frac{d_n}{E_a}$$

where

d_t = Total amount of irrigation water to be applied at each irrigation application, mm
 d_n = Net amount of irrigation water to be applied at each irrigation application, mm
 E_a = Water application efficiency.

In drip irrigation method, the water application efficiency may be taken as 90% in systems where the operation unit is small and the laterals are short, and as 85% in systems where the operation unit is relatively large and the laterals are long. In systems where drippers with pressure regulators, these values may be increased by 5%.

In drip irrigation method, the irrigation duration is calculated by the equation:

$$T_a = \frac{1000d_t}{qN}$$

where

T_a = Duration of irrigation, h

d_t = The total amount of irrigation water to be applied, mm

q = Dripper flow rate, L/h

N = The number of drippers per decare area, number/da.

4.6.5. Fertigation and the Problems Arising in Drip Irrigation Systems and Solutions Thereof

The most important problem in fertigation and thus, in drip irrigation systems is the clogging of system elements in time with solid particles, organic compounds and lime. Consequently, fertilizer distribution uniformity may also break down in time. There are 5 main reasons to low water and fertiliser distribution uniformity in fertigation (Burt, 1998).

1. Growers purchase systems without sufficient conformity to design and planning criteria or designs are unsuitable for the systems,
2. Insufficient filter use,
3. Insufficient washing and cleaning in the system used (filters, pipes, etc.),
4. Using the chemicals in fertigation without controlling their conformities with each other,
5. Reusing the system elements which appear good in practice.

Therefore, for a successful application in micro irrigation and fertigation, it is necessary that a suitable filtering and suitable chemicals (such as acid, chlorine) are used, the effects and other properties of the fertilisers and other chemicals must be carefully and consciously used and the system must periodically be washed.

Clogging: In drip irrigation systems, solid particles and microorganisms clog small orifices and dripper. In addition, precipitation of the fertilisers within the system is one of the most important issues. When the necessary precautions are not taken, the mineral deposits (residues) in the pipes and drippers accumulate in time and cause clogging. These deposits (residues) are generally calcium and magnesium carbonates and iron oxides. These are formed when the pH of the irrigation water is above 7.0.

Physical formations (Suspended solid particles)	Chemical formations (precipitation)	Biological formations (Bacteria and algae)
Inorganic particles sand Silt Clay	Calcium or Magnesium carbonate Calcium sulphate	Slime
Organic particles Aquatic plants (phytoplankton/algae) Aquatic animals(zooplanktons) Bacteria	Heavy metal hydroxides, carbonates, silicates and sulphides Oil and other lubricating materials Fertilisers Phosphates Liquid ammonia Iron, copper, zinc and manganese	Microbial deposits Iron Sulphur Manganese

For example, if the calcium concentration in the irrigation water is above 100 ppm, one of the most important problems is the clogging of the system due to this. If the calcium concentration in

the irrigation water is high and if phosphorous is being injected into the system, precipitation will probably increase. If the irrigation water contains high amount of calcium and magnesium, injection of ammonium phosphate will cause deposit formation in the inner walls of the laterals, in the dripper and in the sprinkler heads, and this ultimately cause complete clogging of the system. Some solutions may form precipitates due to temperature and/or pH changes. These solutions or residues in the pipe and dripper may cause less water to pass through the drippers and complete clogging of the system in time. Thus, calcium and iron precipitates is a potential problem for most waters.

Analyses to be made in the irrigation water may give an idea whether bicarbonate or iron concentrations will cause precipitate formation. As a general rule, a bicarbonate concentration above 2.0 me/L and a pH more than 7.5 will probably for a calcium precipitation. Figure 4.23 lists the physical, chemical and biological formations that cause clogging in micro irrigation systems.

When the system is clogged due to bicarbonate precipitation, acid reactive fertilise use will partly solve the problem. However, acidic fertilisers may damage metallic fittings and asbestos-cement pipes. Thus, in fertigation, periodic acid use is recommended to prevent clogging in the drippers and to dissolve the deposits. To this end, phosphoric acid, sulphuric acid or hydrochloric acid may be used. Hydrochloric acid (HCl) may be used in general as it is cheap. Acid injection to the system may also remove the algae, bacteria and slime deposits. After acid injection, the system must carefully be washed.

Washing and filtering: To prevent clogging in the system, the system must be well maintained and repaired, the system elements must be washed and cleaned from time to time, there must be filtering and chemicals (such as acid, chlorine) must be used. For washing operations, there must be washing valves at the end of the primary and secondary (manifold) pipelines, and also for lateral lines. To support filtering there must be valves at the end of dripper lines. If the concentrations of clay, silt and biological wastes are very high in the irrigation water, automatic washing will be very useful. On the other hand, the system must be well cleaned and washed at the start, middle and end of the season. For washing, the flow rate of water in the system must be at least 0.3×0.6 m/s (ASAE, 1998).

The most important devices in drip irrigation systems are the filters, which ensure that clean water enters the system. The undesired organic and inorganic materials in the irrigation water are held back by filters. Thus, the filters must be washed frequently or with certain periods. If not meticulously maintained, there may be water load loss of about 1 atm (= 10 Mss) in sand gravel and fine sieve filters. Recent systems automatically wash themselves, parallel to the progress of automation. However, for a good irrigation performance the control unit and the filters must be continuously controlled and maintained. Sieve filters are generally clogged by fertilisers. They must be washed before every irrigation to remove the adhesive or depositing fertiliser remains away from the system and to ensure a well fertilisation and the required flow. In a drip irrigation system there are respectively sand separator (hydrocyclone), sand gravel filter, fertiliser tank filter and fine sieve and or disk filter. The fine sieve or the disk filter is placed after and the other filters before the fertiliser or chemicals tank.

Sand separator (hydrocyclone): If there is the risk of the presence of sand and silt in the irrigation water taken from the resource (both are heavier than water), these sand and silt particles must be withheld before they enter the system. This is done by the traction of the centrifugal force formed due to narrowing of the water which progresses under a certain pressure. The irrigation water enters from the wider part, sand particles remain at the bottom of the system and the water, refined from sand, moves up with the centrifugal force and is given to the system.

Sand-Gravel filter: This filter contains sand-gravel and is generally used for retaining the particles suspended (clay, algae, weeds, leaves, etc.) in water. It may be made of stainless metals or hard plastics. It must be automatically or manually cleaned from time to time by back-washing.

Fine Sieve or disk filter: This filter is generally placed after the fertiliser tank in the system. To withhold the fertiliser deposits that may come from the sand gravel tank and the fertiliser tank and that

could not be retained in the hydrocyclone and sand-gravel filter, disc or sieve filters must be used. In general, sieve filters will vary between 80-200 mesh. The most commonly used ones are between 120-160 mesh.

Chemicals Used to Prevent or Remove Clogging

1. Acid Application: Acid applications are used for reducing insoluble deposits and chemical precipitates. Acid application is not effective against sedimentation of organic materials. Acids may be very corrosive and damaging. Therefore, they must not be contacted to metallic parts, glued places or places where asbestos adhesives have been used. Thus, they must not be used unless necessary and utmost care should be taken when using them. The most convenient way to use them to prevent clogging is to apply the acid to the system for 45-60 minutes. Commonly, phosphoric acid (this provides also phosphorous to the soil), sulphuric acid, hydrochloric acid and nitric acid are used. In the choice of the acid, the cost, quality of the available water, the status of the clogging and nutrient needs of the plants (e.g., phosphorous) should be considered.

To determine the amount of acid to be applied to the system the strength of the acid, buffering capacity of the irrigation water, and the pH value of the irrigation water to dissolve the precipitates must be known. This may be determined by carrying out a titration test on the available irrigation water, decreasing its pH to the pH desired. For this, a container of known volume, irrigation water, the acid to be used, pipettes and a pHmeter is required. For example, a 10 L container, in which there is the irrigation water, about 1-3 ml acid to be used is added and stirred. Then, the pH is measured using the pHmeter. This treatment is repeated until the pH of the irrigation water reaches the desired level (for example, if it is intended to apply acid to the system for 45-60 minutes, it is sufficient that the pH of the irrigation water is 4.0 – 5.0). This way, the amount and/or volume of the acid to be used in the available volume of the irrigation water is determined. Since this application is to be done during the irrigation, precipitate accumulation in the pipes and the drippers is prevented. Based on this, it can be determined how much or at which speed the acid will be added to the system.

For example, in the titration method, 10 ml phosphoric acid is used to decrease the pH of the irrigation water in a 100 L volume container to 4.5 (pH level of the irrigation water to prevent formation of precipitates in the irrigation system). The system flow rate is 10 L/s. What will be the acid application rate that should be used?

Since 10 ml phosphoric acid is used for 100 L irrigation water, we get $10 \text{ ml}/100\text{L} = 0.10 \text{ ml acid/L}$ irrigation water, and the acid application rate is found to be $0.10 \text{ ml/L/s} = 1 \text{ ml/s}$. This means that if phosphoric acid is applied at 1 ml/s rate to the irrigation system with 10 L/s flow rate, the pH of the irrigation water will be approximately 4.5, which in turn gives acid application for 60 ml/min or 3600 ml/h = 3.6 L/h. If the application will be carried out for 45 minutes, then $45/60 \times 3.6 = 2.7 \text{ L}$ phosphoric acid is required.

On the other hand, the recommended acid amount in shock applications for example to remove the lime precipitations is generally the application of 33% hydrochloric acid at the 0.6% level. An application duration of 10-15 minutes is sufficient. Here, high acidity is applied to dissolve the accumulated deposits. When low concentration acid is used continuously, precipitate accumulation is prevented.

Consequently, the way to dissolve bicarbonate is applying acid to the system. To eliminate the excess bicarbonate a cheap acid at sufficient concentration must be chosen. Despite this, if the pH of the irrigation water is between 5.5-7.0, the excess bicarbonate in the irrigation water is eliminated. For a sufficiently low pH, it is recommended to apply acid between 0.02-0.2% of the system capacity.

Sulphuric acid (H_2SO_4) application can relatively increase the acidity of the root zone of the plant in a more uniform and rapid manner. However, to apply this acid equipments which are nor economical for private, small fields. In applying N, phosphoric acid to the soil by applying urea-sulphuric acid, P is also applied to the soil. As a general rule, phosphoric acid is more expensive than urea-sulphuric acid. Sulphuric or phosphoric acid application requires special equipment. Urea-sulphuric acid is buffered with urea and does not speed up equipment use much. In general, urea-sulphuric acid operates better in plastic materials.

After acid application, the system must be washed well with the available irrigation water,.

As mentioned above, the biggest problem in drip irrigation systems is the clogging of pipes and drippers. To prevent this, acid and chlorine must be applied from time to time. To determine the amount and how to apply these chemicals, firstly, the system entrance rate (or the injection rate) of the chemicals must be known, which can be calculated by the equation below (Keller and Bleisner, 1990).

$$q_c = K \frac{u \cdot Q_s}{c^1}$$

where

q_c = System entrance rate of the applied chemical, L/h

K = Conversion coefficient, 3.6×10^{-3}

U = Desired amount of the chemical in the irrigation water, ppm or mg/L

Q_s = Capacity – flow rate of the irrigation system, L/s

c^1 = Concentration of the desired chemical (compound) in the liquid chemical solution (in the stock tank), kg/L or %.

Exemplary calculation for acid application

In the last 15 minutes of the irrigation, HCl will be used to dissolve the lime accumulated in the pipes and drippers. For this, the amount of HCl in the irrigation water is desired to be 0.5% (= 5000 ppm). The acid to be used is 20% HCl, with a density of $d = 1.1 \text{ g/cm}^3$. The system flow rate is 5 L/s. According to these, find the acid application rate and the amount of acid required.

Solution:

$$q_c = K \frac{u \cdot Q_s}{c^1}$$

$$c^1 = 1.1 \times 0.20 = 0.22$$

Acid application rate

$$q_c = K \frac{u \cdot Q_s}{c^1} = 3.6 \times 10^{-3} \frac{5000 \cdot 5}{0.22} = 409 \text{ L/h} = 6.8 \text{ L/min} = 113.6 \text{ ml/s}$$

Amount of acid required

The tank in which the acid will be placed is 100 L, and the ratio between the system acid entrance rate from the acid tank and the system flow rate is required. The system flow rate is 5 L/s and the acid application rate is 409 L/h. Thus, since $5 \text{ L/s} = 18\,000 \text{ L/h}$, $18\,000 / 409 = 44$. This is, as 44 units of irrigation water is supplied from the irrigation system, 1 unit of acid is supplied from the acid tank. That is, the ratio is 1/44. According to this, the amount of acid required can be calculated as follows:

5% HCl (= 5 000 ppm = $5 \times 10^{-3} \text{ kg/L}$)

$$= \frac{x}{100} \times \frac{20}{100} \times 1.1 \frac{1}{44}$$

$X = 100 \text{ L}$

100 L of this acid is taken and according to the system properties give above, i.e., according to 409 L/h acid application, approximately 100 l will be applied in 15 minutes. In this case, in 15 minutes, the HCl level in the irrigation water will be 0.5% or 5 000 ppm.

Chlorine application: Organic matter such as algae and slime formed by the bacteria in the irrigation water clog the pipes and the drippers. This can be prevented by chlorination. In such a case, generally, application of chlorine is recommended at 1 ppm during the irrigation or 10-20 ppm in the last 20 minutes of irrigation. When there is more clogging, a shock application at a higher concentration (such as 100-200 ppm) and a shorter duration may be carried out (Wheeler and Brown, 2001).

In chlorination, most commonly used chemical is liquid sodium hypochlorite (Na(OCl)). Calcium hypochlorite ((Ca(OCl)₂) is used in swimming pools but is not recommended for use in irrigation systems due to the risk of precipitate formation (since it increases the pH of the irrigation water).

On the other hand, when there is even 0.3 ppm iron in the irrigation water, this may form precipitate in drip irrigation systems. Chlorination, as a chemical application will ensure the oxidation of iron. Thus, it is recommended that 1-2 ppm chloride is applied to the irrigation water for 30-60 minutes.

In addition, chelating iron with a phosphate chelate may prevent precipitation of iron. If iron is more than 10 ppm, the irrigation water must be ventilated to ensure oxidation. In general, applications of chlorine doses to prevent precipitation of various organic matters and iron are recommended by Keller and Bleisner (1990) as follows:

In the irrigation systems, for algae, having 1 ppm chlorine in the irrigation water during irrigation or 20 ppm chlorine in the last 20 minutes of the irrigation; for hydrogen sulphide, using chlorine that is 3.6 – 8.4 times the hydrogen sulphide; for iron bacteria, using chlorine that is 1 ppm plus the existing amount of iron in the irrigation water; to prevent the precipitation of iron, using chlorine that is 0.64 times the Fe+2 content at the end of the laterals so that there is 1 ppm free chlorine; to prevent the precipitation of manganese, using chlorine that is 1.3 times the Mn content; and to prevent other formations such as slime, chlorine application so that there is 1 ppm chlorine at the end of the lateral is recommended. On the other hand, different levels of pH in the irrigation water will have different effects on the biological activity of chlorine. Hypochloric acid (HOCl) is 80 times more effective than the hypochlorite ion (OCl⁻). At pH 5, more than 90% chlorine is in the form of HOCl. This ratio is 60% at pH = 7, and 40% at pH = 7.5. In the light of these explanations, as the pH of the irrigation water increases, the effectiveness of chlorine decreases. Therefore, when chlorine is being added to the irrigation water, acid is also added to decrease the pH. However, acid must never be added over chlorine because chlorine gas at a deadly level will form (Wheeler and Brown, 2001).

When chlorine is added to the system, equation 9.1 is used to determine the application rate and amount of chlorine. An exemplary solution is given below.

Exemplary calculation for chlorine application:

It is desired that the irrigation water ha 15 ppm chlorine. The system capacity is 15 L/s and 2% sodium hypochlorite will be used. According these data, what will be application rate of chlorine?

Solution:

$$q_c = K \frac{u \cdot Q_s}{c^1} = 3.6 \times 10^{-3} ((15 \times 15) / 0.12) = 7 \text{ L/h}$$

Chlorine application rate is found as follows:

In a system where the chlorine application rate is 8 L/h, the flow rate of the irrigation water is 12 L/s. 12% sodium hypochlorite will be used. According these data, what will be the chlorine level in the irrigation water?

Solution:

$$q_c = K \frac{u \cdot Q_s}{c^1}$$

When the above equation is rearranged to get u and the other values are placed, u will be found to be 22 ppm.

- Important points to be complied with in fertigation
- ❖ To appropriately and effectively use the fertilisers and other chemicals in fertigation it is very important that the information given below are complied with (Burt, 1998).
- ❖ The chemicals must be given (injected) to the system before the fine filter. However, under strong acid or very low pH conditions, it may be injected after the filter so that the filter is not damaged.
- ❖ The chemicals must be injected to the system at the centre of the system entrance pipe so that they are mixed well.

- ❖ When using solid, water soluble fertilisers, for a through mixing, at most 50-75% of the container should be filled with the fertiliser.
- ❖ Before adding solid, water soluble fertiliser to the fertiliser tank, always liquid fertiliser must be added to the liquid in the mixing container (the liquid added provides some heat so that the solid fertilisers have characteristics to cool the solution).
- ❖ To prevent soluble or insoluble large formations, the fertiliser mixtures must be added slowly to the fertiliser tank.
- ❖ The amount of fertiliser in the irrigation system must be at most 5 g/L.
- ❖ When using acid, always add acid to the water, and not the water to the acid.
- ❖ When chlorinating with chlorine gas, always add chlorine to the water.
- ❖ Never mix an acid or an acidic fertiliser with chlorine. Acid and chlorine must not be kept in the same room.
- ❖ An acid should not be mixed with anhydrous ammonia or liquid ammonia; a very severe and sudden reaction will occur.
- ❖ A concentrated fertiliser solution must not be mixed with another concentrated fertiliser solution.
- ❖ A compound containing calcium must not be mixed with a compound containing sulphate because an insoluble gypsum mixture will form.
- ❖ Information concerning whether the fertilisers comply with each other and the solubilities thereof must be acquired and must be used only after such information is checked.
- ❖ If the chemicals used have very low concentrations and if they do not comply with each other, the fertilisers used will have no efficacy.
- ❖ As far as possible, fertilisers containing phosphate and fertilisers containing calcium should not be used.
- ❖ Very hard waters (which have relatively high calcium and magnesium content) should not be used because hard waters make the phosphate, neutral phosphate, and sulphate compounds insoluble.
- ❖ In chemical injection systems, equipments preventing backflow must be used.
- ❖ Water counters must be calibrated at each different chemical application because the density and viscosity of the chemicals effect the readings of the water counters.

4.7. Under-Tree Micro Sprinkler Irrigation Method

In the under-tree sprinkler irrigation method, small sprinkler heads are commonly used to irrigate orchards. The sprinkler irrigation method where small sprinkler heads are used is called the under-tree sprinkler irrigation method. The elements of this system are the same as the elements of the drip irrigation system, the only difference being the use of small sprinkler heads instead of drippers.

In other words, the under-tree sprinkler irrigation system consists of the followings:

- Pump unit,
- Control unit,
- Main pipeline,
- Manifold pipelines,
- Lateral pipelines,
- Small sprinkler heads.

In this method, a lateral line is installed at each tree row and a sprinkler head is placed under each tree along this lateral. In the under-tree sprinkler irrigation method, the operation pressure is about 1-2 atm. The flow rates of the heads change between 30-200 L/h. A sprinkler head generally wets an area about the projection of the tree crown. Thus, on the row and between the rows there may be a dry area that is not wetted. In this method, the distance between the heads is equal to the distance between the trees on the row and the lateral interval is equal to the distance between the tree rows.

The small sprinkler heads used in irrigating fruit trees may be fixed or the revolving type. Every establishment manufacturing small sprinkler heads are obliged to supply the designer or the operator a table showing the technical specifications of the head. In this technical table, there must be optimum operation

pressures, head flow rates, wetting diameters and sprinkler rates. The system is designed and operated according to these values.

In small sprinkler heads, the average sprinkling rate is calculated by the following formula:

$$I_y = \frac{4q}{\pi D^2}$$

I_y = Sprinkling rate, mm/h

q = Head flow rate, L/h

D = Head wetting diameter, m.

This value must be equal to or less than the water infiltration rate of the soil. In orchards, in systems where a small sprinkler head is placed under every tree, the percentage of the wetted area is calculated using the below formula:

$$P = 100 \frac{\pi D^2}{4S_s S_a}$$

P = Percentage of the wetted area, %

D = Wetting diameter, m

S_a = Tree interval on the row, m

S_s = Tree row interval, m.

The percentage of the wetted area must not be below 30%.

In the micro sprinkler irrigation method, the duration of irrigation is calculated using the below formula:

$$T_a = \frac{d_t}{I_y}$$

The calculation of the amount of irrigation water to be applied at each irrigation application, irrigation interval and the consumptive water use is like the calculation in the drip irrigation method. In this method, in general, irrigation is started when 40% of the usable water holding capacity is consumed ($R_y=0.40$) and the water application efficiency is about 70% on the average ($E_a=0.70$).

In the micro sprinkler irrigation method, a lateral is placed at every tree row and a micro sprinkler head is placed at every tree, the sprinkling rate not being greater than the rate of infiltration of water into the soil. In the micro sprinkler irrigation method, the ratio of the wetted area must considered to be at least 25% and at most 50% in humid regions.

In under-tree irrigation of orchards, specially made, small sprinkler heads are used. In this system, a polyethylene (PE) lateral pipeline is spread on the surface at each tree row and a specially made, small sprinkler head is placed under each tree. The system is completely fixed, and at the end of the irrigation season only the sprinkler heads are collected if desired. Such systems are also called under-tree micro sprinkler system. A sprinkler head wets an area approximately equal to the tree crown.



Advantages: The advantages of this system in addition to the other sprinkler systems are as follows:

- ❖ Agricultural activities are not hindered since all the water transmission system is embedded.
- ❖ The system has a long life and is not susceptible to damage by birds and rodents since the system is completely embedded.
- ❖ The method is conveniently compatible with the root development of the tree.
- ❖ The initial installation costs are lower compared to that of the normal sprinkler systems.
- ❖ Since the nozzle holes are larger than drip irrigation, a larger mesh filter can be used.
- ❖ The root structure of the tree can extend naturally because a larger area can be wetted compared to drip irrigation method.
- ❖ In normal sprinkler systems, fungal diseases develop on the fruits and leaves because the tree crown gets wet during irrigation, thus, they cannot be used, but here mini sprink can safely be used.

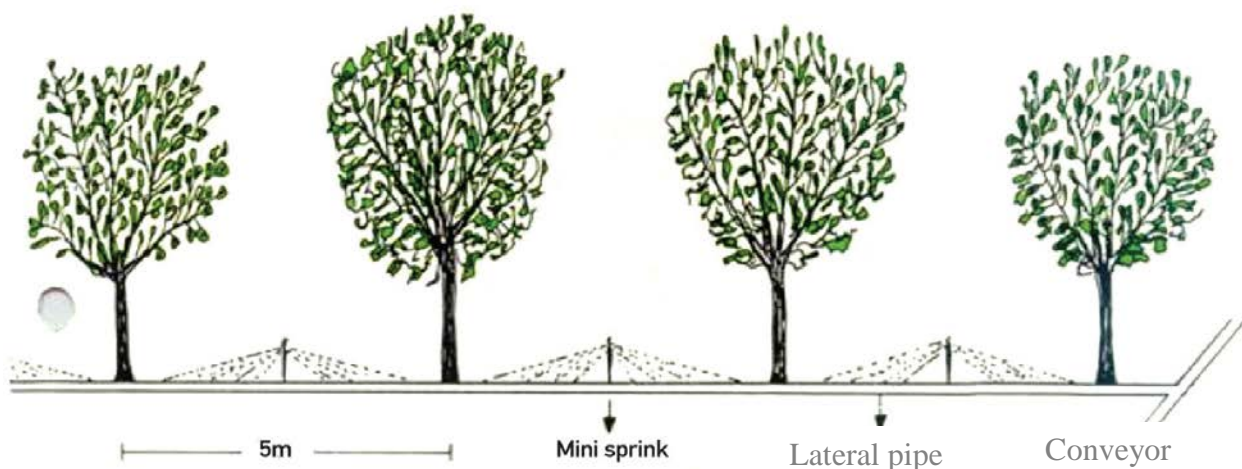

4.8. In- Ground Irrigation Method

In the in-ground irrigation method, water infiltrates to the root zone of the plant from underground. To this end, deep field dikes opened at certain intervals to control the underground water or perforated or permeable pipelines are installed under the ground.

In the field dike system, the underground water is kept at a certain depth. Water rises to the root zone starting at the underground water level by capillarity to meet the water need of the plant. The in-ground irrigation method with field dikes is very limited and has almost been abandoned.

Perforated or permeable pipelines operating under pressure are placed under the ground at frequent intervals and generally at shallow levels. Some of these can operate under very low pressures such as 1 m. water that infiltrates into the soil from these pipelines is distributed in the root zone by the help of gravity and capillarity. The necessary system pressure is provided by a pump or a water tank installed at a high place. The water distribution system consists of the pump unit, water tank, control unit, main pipelines, manifold pipelines, and lateral pipelines.

All the manifold and lateral pipelines are embedded in the soil. Thus, the initial installation costs are very high. In addition, clogging in the lateral pipelines, which are perforated or permeable, brings up significant problems. Thus, pressurised infiltration irrigation method is used rarely in practice, under special circumstances.

PROJECT EXAMPLES

Drip Irrigation Project Examples

PROJECT EXAMPLE 1: DRIP IRRIGATION PROJECT

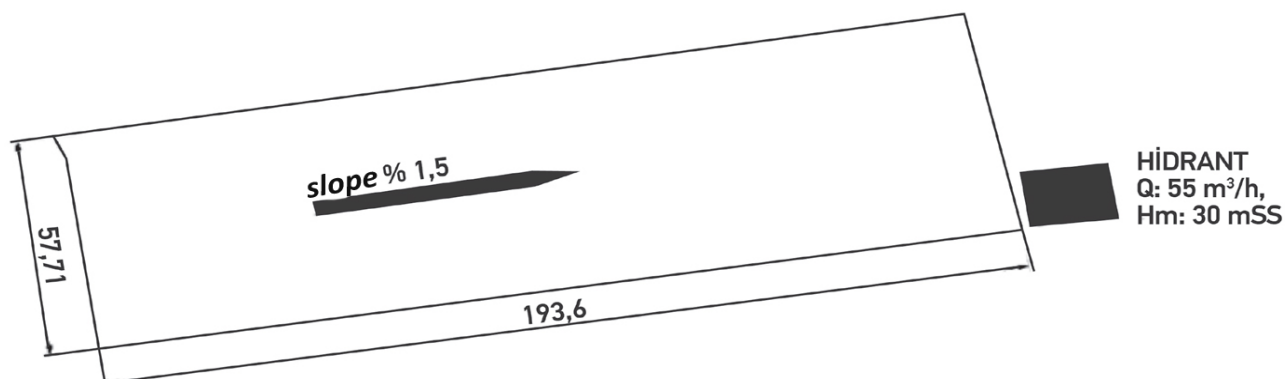

COTTON (Şanlıurfa - Centre)

Area	:10 da
Soil Structure Class	: Clayey loam
Cotton Planting Spacings	: Ss x Sa = 0.70 x 0.15 m
Maximum Consumptive Water Use of the Plant	: E.T= 6.7 mm/day
Seasonal Total Irrigation Water Need	: 1480 mm/season
Total Amount of Irrigation Water	: 1036 mm
Hydrant (canalette) Flow Rate	: Q = 12 L/s
Irrigation Water Quality Class	: C2 S1
Usable Water Holding Capacity	: dk= 180 mm/m
Water Intake Rate	: I = 13 mm/h
Effective Root Depth	: 90 cm

Monthly consumptive water use of the plant as calculated by the Penman – Monteith method in the CROPWAT software are as follows:

Month	Avg Temp °C	Humidity %	Wind m/s	Sun hours	Rad MJ/m²/day	ETo mm/day
January	5.8	71	0.9	4.1	7.8	0.85
February	7.1	67	1.0	5.0	10.6	1.23
March	11.1	62	1.1	6.2	14.8	2.04
April	16.3	58	1.2	7.7	19.3	3.19
May	22.5	47	1.3	9.6	23.6	4.71
June	28.4	36	1.6	11.4	26.8	6.39
July	32.2	33	1.7	11.7	26.8	7.14
August	31.4	37	1.5	11.4	24.9	6.44
September	26.9	40	1.3	10.1	20.5	4.82
October	20.3	49	0.9	8.2	14.8	2.91
November	12.6	62	0.9	6.0	9.9	1.49
December	7.5	71	0.8	4.2	7.3	0.86
Average	18.5	53	1.2	8.0	17.3	3.50

Monthly consumptive water use of the plant calculated in accordance with the drip irrigation method by the Penman – Monteith method in the CROPWAT software are as follows:

	ETo mm/day
January	0.0
February	1.2
March	1.9
April	3.0
May	4.0
June	6.0
July	6.7
August	6.0
September	4.5
October	2.6
November	1.4
December	0.8
Average	3.3

Process Steps:

1. Operation Pressure:

As pressure is provided by a pump, it is assumed $h_o = 1.0$ atm.

2- Optional Dripper Flow Rates:

Optional dripper flow rates at 1.0 atm operation pressure (in accordance with market conditions)

$$q = 1.2 \text{ L/h}$$

$$q = 2.0 \text{ L/h}$$

$$q = 4.0 \text{ L/h}$$

3- Dripper Spacings in Optional Dripper Flow Rates:

For $q = 1.2 \text{ L/h}$; $S_d = 0,9x \sqrt{q/I}$

$$S_d = 0,9 \times \sqrt{1.2/13} = 0,27 \text{ m (assumed to be 0.30 m as it cannot be found on the market)}$$

For $q = 2.0 \text{ L/h}$; $S_d = 0,9x \sqrt{q/I}$

$$S_d = 0,9 \times \sqrt{2.0/13} = 0.35 \text{ m (assumed to be 0.40 m as it cannot be found on the market)}$$

For $q = 4.0 \text{ L/h}$; $S_d = 0,9x \sqrt{q/I}$

$$S_d = 0,9 \times \sqrt{4.0/13} = 0.49 \text{ m (assumed to be 0.50 m as it cannot be found on the market)}$$

4- Ratio of Wetted Area:

$$P = k \times (S_d / S_l), k = 1.0$$

For $q = 1.2 \text{ L/h}$; $P = 1.0 (0.30 / 0.70) = 0.43 = \% 43$

For $q = 2.0 \text{ L/h}$; $P = 1.0 (0.40 / 0.70) = 0.57 = \% 57$

For $q = 4.0 \text{ L/h}$; $P = 1.0 (0.50 / 0.70) = 0.71 = \% 71$

P must be ≥ 0.30 . Of these drippers, the 1.2 L/h, 2.0 L/h and 4.0 L/h drippers provide the suitable wetting area; however, the drippers with 2.0 L/h have been chosen not to increase the system cost.

4- Suitable Dripper Flow Rate:

The $q = 2.0 \text{ L/h}$ dripper flow rate is considered appropriate.

In this project, the dripper with a flow rate of 2.0 L/h at 1.0 atm operation pressure is chosen.

The distance between two laterals;

$$S_l = k \times S_d = 1.0 \times 0.70 = 0.70 \text{ m.}$$

PRELIMINARY PROJECT FACTORS

Dripper flow rate : 2.0 L/h

Dripper spacing (S_d) : 0.40 m

Lateral spacing : 0.70 m

Ratio of wetted area (P) : 0.57

Soil depth to be wetted by irrigation:

Effective root depth is assumed to be equal to effective soil depth.

$D = 90 \text{ cm} = 0.90 \text{ m}$

SYSTEM LAYOUT:

Lateral pipelines must be either parallel to contour lines or they must have down slope inclinations. Manifold pipelines must be perpendicular to the laterals, they must have no slope or must be down slope. Main pipelines follow the parcel borders as far as possible.

1) Lateral Pipe Diameter:

a) Lateral length, $L_l = 98 \text{ m}$

b) Number of drippers on the lateral

$n_d = L_l / 0.40 = 245$

c) Lateral Flow Rate

$Q_l = n_d \times q = 245 \times 2.0 = 490 \text{ L/h}$

d) Lateral Slope

$S_l = \% 1.5 \text{ (down slope)} \quad E_o = 0.662 \text{ and } L_o = 0.288$

e) Operation Pressure

$h_o = 1.0 \text{ atm} = 10 \text{ m}$

f) It is decided that the lateral pipeline is made of PE drip irrigation pipes with 4 atm operation pressure

g) Lateral Pipe Diameter

20 mm diameter lateral pipe at 1.0 operation pressure, with 2.83 m load loss and 0.60 m/s flow rate is chosen in accordance with Williams Hazen.

14) Lateral Entrance Pressure

$H_l = h_o + E_o \times h_{fl} - L_o \times h_{gl}$

$H_l = 10 + 0.662 \times 2.83 - 0.288 (0.015 \times 98)$

$H_l = 11.45 \text{ m}$

15) Manifold Pipe Diameter

a) Manifold Length

$L_m = 60 \text{ m}$

b) Number of laterals on the Manifold

$n_l = 86$

c) Manifold Flow Rate

$Q_m = n_l \cdot q = 86 \times 490 = 42\,140 \text{ L/h}$

d) Manifold Slope

$S_m = \% 0 \text{ (no slope)} \quad E_o = 0.738 \text{ and } L_o = 0.370$

e) Lateral entrance pressure

$H_l = 11.45 \text{ m}$

f) Manifold pipelines must be of hard PE pipes with 6 atm operation pressure.

g) Manifold Pipe Diameter

Under conditions of 1.42 m load loss and 1.59 m/s average flow rate, pipe diameters are chosen as follows, in accordance with William Hazen.

$\varnothing 110/6 - 60 \text{ m}$

Manifold pipelines will be made of PE pipes with 6 atm operation pressure.

Manifold entrance pressure

$H_m = H_l + E_o \times h_{fl} - L_o \times h_{gl}$

$= 11.45 + 0.738 \times (1.42) + 0.370 \times (60 \times 0.0)$

$= 12.50 \text{ m}$

16) Main Pipe Diameter

a) Main Pipe Length

$$L_a = 194 \text{ m}$$

b) Number of manifolds on the main pipe

$$n_a = 1$$

c) Main Pipe Flow Rate

$$Q_a = Q_m \times 1 = 42.14 \text{ L/h}$$

$$H_m = 12.50 \text{ m} \pm 1.5 \text{ (up slope)} \quad E_o = 0.717 \text{ and } L_o = 0.362$$

d) Main pipelines must be of hard PE pipes with 6 atm operation pressure.

e) Main Pipe Diameter

Under conditions of 18.90 m operation pressure, 4.45 m load loss and 1.59 m/s average flow rate, pipe diameters are chosen as follows, in accordance with William Hazen

$$\varnothing 110/6 - 194 \text{ m}$$

f) Main pipe entrance pressure

$$\begin{aligned} H_a &= H_m + E_o \times h_{fl} - L_o \times h_{gl} \\ &= 12.50 + 0.717 \times 4.45 + 0.362 \times (194 \times 0.015) \\ &= 16.74 \text{ m} \end{aligned}$$

g) Pressure desired in the main pipe

$$H_a = H_m + h_y = 16.74 + 0.26 = 17 \text{ m.}$$

h) System flow rate

$$Q = Q_m = 42.14 \text{ m}^3/\text{h} = 11.7 \text{ L/s}$$

ELEMENTS OF THE CONTROL UNIT

As the water source is hydrant with the pipe system from the open channel, there will be algae, suspended matter and sand in the irrigation water. Therefore, the elements of the control unit are as follows:

Algae (Graver) Filter

Disc Filter

Fertiliser tank

FERTILISER TANK:

$$V = (F \cdot A) / C$$

At the design stage, it is assumed that $F = 3.5 \text{ kg/da}$, $C = 0.5 \text{ kg/l}$.

$$V = 70 \text{ L}$$

ALGAE FILTER: Load losses 0.95 m

DISC FILTER: Load losses 0.18 m

FITTINGS: 0.97 m

PUMP EXIT PRESSURE: $H_h = H_a + H_f = 17 + 0.95 + 0.18 + 0.97 = 20.10 \text{ m.}$

MANOMETER HEIGHT: $H_m = H_h + H_{de} = 20.1 + 1 = 21.10 \text{ m.}$

Hydrant properties: $H_m = 21.10 \text{ m}$, $Q = 11.7 \text{ L/s}$.

Implementation of the project on the land:

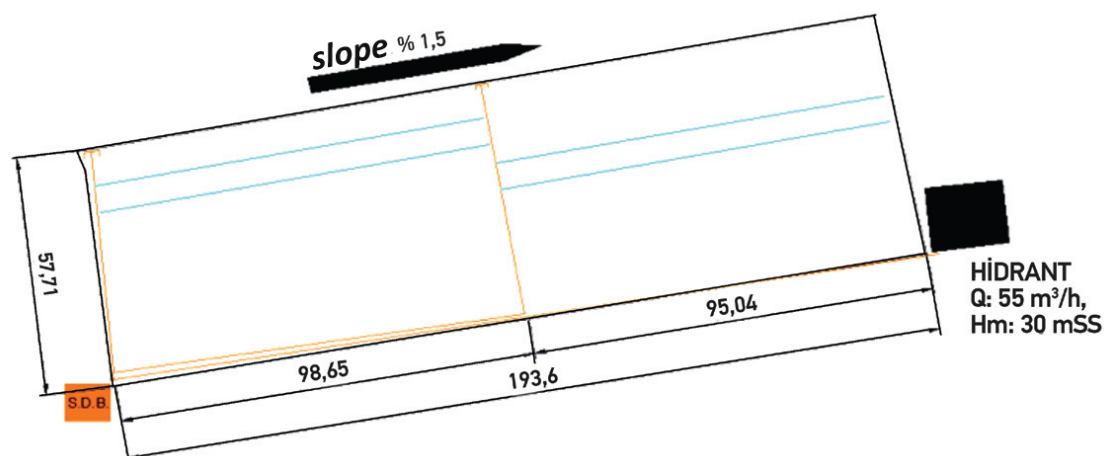

Materials bill of quantity of the project:

No.	TYPE OF MATERIAL	AMOUNT	UNIT
1	(2"X2")4" Single Backwash Algae (Graver) Filter Unit	1	ea
2	70 L Fertiliser Unit	1	ea
3	Ø110 / 4 Atu Pe Clipped Pipe	330	m
4	Ø110 / 4 Atu Pe Clipped Pipe Gasket	55	ea
5	Ø110 / 4 Atu (1 Meter) Pe Clipped Pipe	2	ea
6	20/40/2.0 In-Line Drip Lateral	14400	m
7	110 X 4 " Pe Clipped Male Motopomp	2	ea
8	Ø 110 Pe Clipped Pipe Bracket	3	ea
9	Ø 110 Pe Clipped Te	2	ea
10	Ø110 Pe Clipped Male Blind Plug	3	ea
11	Ø 110 Clipped Line Valve	2	ea
12	20 mm Nipple	200	ea
13	20 mm Drip Nail Gasket	200	ea
14	20 mm Insert Blind Plug	200	ea
15	Teflon Band	15	ea

The Irrigation Schedule (IS) calculated after the project is implemented on the land by the Penman-Monteith method with the CROPWAT software and monitoring form:

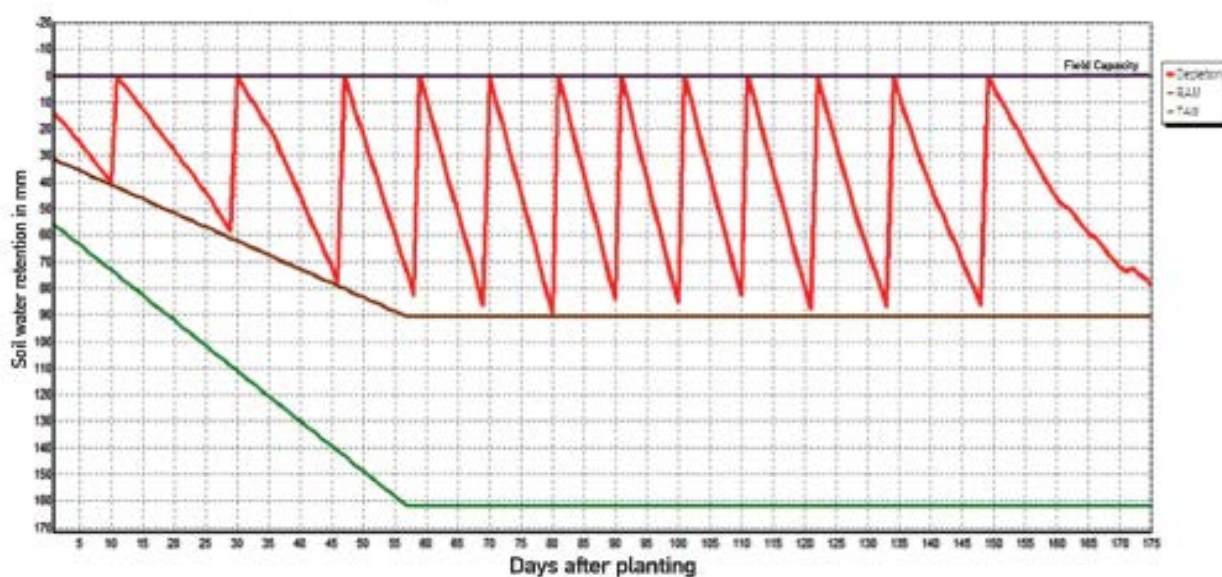

Date	Days	Period	Amount of Net Irr. Water (mm)
25 April	11	Initial	42.7
14 May	30	Budding	62.3
31 May	47	Budding	83.1
12 June	59	Pod	91.4
23 June	70	Pod	94.9
04 July	81	Pod	99.0
14 July	91	Pod	93.9
24 July	101	Pod	94.9
03 August	111	Pod	91.5
14 August	122	Pod	96.2
26 August	134	Maturing	94.1
10 September	149	Maturing	92.1
		Total	1036.1

**PROJECT EXAMPLE 2
DRIP IRRIGATION PROJECT**

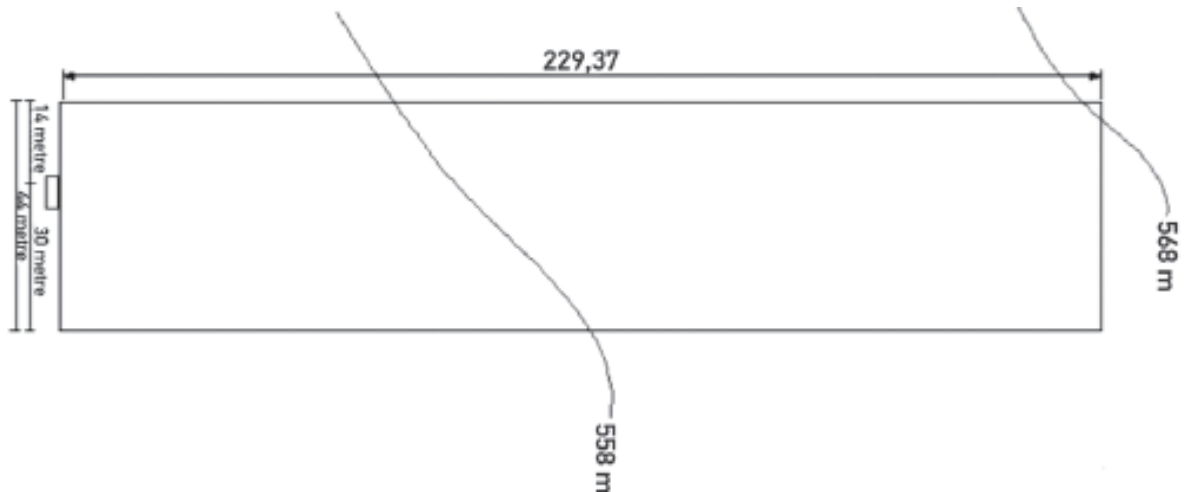

ANTEP PISTACHIO (Ş. Urfa-Bozova)

Area	: 10 da
Soil Structure Class	: Clayey loam
Planting Spacings	: $S_s \times S_a = 7.0 \times 7.0$ m
Maximum Consumptive Water Use of the Plant	: ET= 4.6 mm/ day
Seasonal Total Irrigation Water Need	: 794 mm/ season
Total Amount of Irrigation Water	: 556 mm
Hydrant Flow Rate	: $Q = 7$ L/s
Usable Water Holding Capacity	: $dk = 160$ mm/m
Water Intake Rate	: $I = 7$ mm/h
Effective Root Depth	: 120 cm

Monthly consumptive water use of the plant as calculated by the Penman – Monteith method in the CROPWAT software are as follows:

Monthly ETo Penman-Monteith - C:\ProgramData\CROPWAT\data\climate\ŞANLIURFA\BOZ...						
Country		TÜRKİYE		Station ŞANLIURFA/BOZOVA		
Altitude		542 m.		Latitude		37.45 °N
				Longitude		38.35 °E
Month	Avg Temp	Humidity	Wind	Sun	Rad	ETo
	°C	%	m/s	hours	MJ/m ² /day	mm/day
January	3.5	60	0.5	4.1	7.8	0.79
February	5.0	60	0.5	4.4	10.0	1.01
March	9.3	55	0.5	6.0	14.4	1.75
April	13.5	52	0.6	6.9	18.2	2.67
May	18.9	44	0.6	9.5	23.5	3.88
June	24.8	35	0.8	11.5	26.9	5.18
July	28.4	34	0.7	11.8	26.9	5.50
August	28.0	37	0.6	10.7	23.9	4.92
September	22.0	39	0.5	9.6	19.8	3.68
October	8.0	47	0.4	7.0	13.4	1.52
November	17.1	54	0.3	5.8	9.7	1.09
December	3.7	60	0.4	4.4	7.4	0.93
Average	15.7	48	0.5	7.6	16.8	2.74

Monthly consumptive water use of the plant calculated in accordance with the drip irrigation method by the Penman – Monteith method in the CROPWAT software are as follows:

Station BOZOVA/DUTLUCA/A.FIS	
	ETo
	mm/day
January	0.6
February	0.8
March	1.4
April	2.2
May	3.2
June	4.3
July	4.5
August	4.6
September	3.0
October	1.3
November	0.9
December	0.8
Average	2.3

Process Steps:

1- Operation Pressure:

As pressure is provided by a pump, it is assumed $h_o = 1.5$ atm.

2- Optional Dripper Flow Rates:

Optional dripper flow rates at 1.5 atm operation pressure (in accordance with market conditions)

$$q = 2.0 \text{ L/h}$$

$$q = 4.0 \text{ L/h}$$

$$q = 6.0 \text{ L/h}$$

3- Dripper Spacings in Optional Dripper Flow Rates:

For $q = 2.0 \text{ L/h}$; $S_d = 0,9 \times \sqrt{q/I}$

$$S_d = 0,9 \times \sqrt{2.0/7.0} = 0,48 \text{ m (assumed to be 0.50 m as it cannot be found on the market)}$$

For $q = 4.0 \text{ L/h}$; $S_d = 0,9 \times \sqrt{q/I}$

$$S_d = 0,9 \times \sqrt{4.0/7.0} = 0.68 \text{ m (assumed to be 0.60 m as it cannot be found on the market)}$$

For $q = 6.0 \text{ L/h}$; $S_d = 0,9 \times \sqrt{q/I}$

$$S_d = 0,9 \times \sqrt{6.0/7.0} = 0.83 \text{ m (assumed to be 0.90 m as it cannot be found on the market)}$$

4- Ratio of Wetted Area:

$$P = k \times (S_d / S_l); \quad k = 1.2.$$

For $q = 2.0 \text{ L/h}$; $P = 0.09 = \% 9$

For $q = 4.0 \text{ L/h}$; $P = 0.11 = \% 11$

For $q = 6.0 \text{ L/h}$; $P = 0.15 = \% 15$

P must be ≥ 0.30 . Of these drippers, the 2.0 L/h, 4.0 L/h and 6.0 L/h drippers do not provide the suitable wetting area. Therefore, it will be calculated again as double lateral layout.

$$P = 2 \times k \times (S_d / S_l); \quad k = 1.2.$$

For $q = 2.0 \text{ L/h}$; $P = 0.18 = \% 18$

For $q = 4.0 \text{ L/h}$; $P = 0.22 = \% 22$

For $q = 6.0 \text{ L/h}$; $P = 0.30 = \% 30$

P must be ≥ 0.30 . Of these drippers, the 6.0 L/h drippers provide the suitable wetting area.

4- Suitable Dripper Flow Rate:

The $q = 6.0$ L/h dripper flow rate is considered appropriate.

In this project, the dripper with a flow rate of 6.0 L/h at 1.5 atm operation pressure is chosen.

PRELIMINARY PROJECT FACTORS

Dripper flow rate	: 6.0 L/h
Dripper spacing (Sd)	: 0.90 m
Lateral spacing	: 7.0 m
Ratio of wetted area (P)	: 0.30

SYSTEM LAYOUT:

Lateral pipelines must be either parallel to contour lines or they must have down slope inclinations. Manifold pipelines must be perpendicular to the laterals, they must have no slope or must be down slope. Main pipelines follow the parcel borders as far as possible.

1) Lateral Pipe Diameter:

a) Lateral length, $L_l = 77$ m

b) Number of drippers on the lateral

$$n_d = L_l / S_d = 85$$

c) Lateral Flow Rate

$$Q_l = n_d \times q = 85 \times 6.0 = 510 \text{ L/h}$$

d) Lateral Slope

$$S_l = \% 5.0 \text{ (down slope)} \quad E_o = 0.510 \text{ and } L_o = 0.230$$

e) Operation Pressure

$$h_o = 1.5 \text{ atm} = 15 \text{ m}$$

f) It is decided that the lateral pipeline is made of PE drip irrigation pipes with 4 atm operation pressure.

g) Lateral Pipe Diameter

16 mm diameter lateral pipe at 1.5 operation pressure, with 7.88 m load loss and 1.02 m/s flow rate is chosen in accordance with Williams Hazen.

14) Lateral Entrance Pressure

$$H_l = h_o + E_o \times h_{fl} - L_o \times h_{gl}$$

$$H_l = 15 + 0.510 \times 7.88 - 0.230 (0.05 \times 77)$$

$$H_l = 18.13 \text{ m}$$

15) Manifold Pipe Diameter

a) Manifold Length

$$L_m = 44 \text{ m}$$

b) Number of laterals on the Manifold

$$n_l = 12$$

c) Manifold Flow Rate

$$Q_m = n_l \cdot q = 12 \times 510 = 6120 \text{ L/h}$$

d) Manifold Slope

$$S_m = \% 1 \text{ (down slope)} \quad E_o = 0.675 \text{ and } L_o = 0.328$$

e) Lateral entrance pressure

$$H_l = 18.13 \text{ m}$$

e) It is planned that Manifold pipelines must be of 6 atm operation pressure.

f) Manifold Pipe Diameter

Manifold pipe diameters are planned at 6 atm operation pressure as follows in accordance with William Hazen.

Ø 50/6 PE pipe 70 m, 6 120 L/h flow rate, 6.12 m load loss and 1.12 m/s rate,

g) Manifold entrance pressure

$$\begin{aligned}H_m &= H_l + E_0 \times h_{fl} - L_0 \times h_{gl} \\ &= 18.13 + 0.675 \times (6.12) - 0.328 \times (44 \times 0.01) \\ &= 22.12 \text{ m}\end{aligned}$$

16) Main Pipe Diameter

a) Main Pipe Length

$$L_a = 230 \text{ m}$$

b) Number of manifolds on the main pipe

Simultaneously $n_a = 1$

c) Main Pipe Flow Rate

$$Q_a = Q_m = 6.12 \text{ m}^3/\text{h}$$

d) Main pipelines must be of PE pipes with 6 atm operation pressure.

e) Main Pipe Diameter

Under conditions of 19.47 m operation pressure, 6.89 m load loss and 1.12 m/s average flow rate, pipe diameters are chosen as follows, in accordance with William Hazen

Ø 50/6 PE pipe 230 m, 6 120 L/h flow rate, 6.89 m load loss and 1.12 m/s rate

g) Main pipe entrance pressure

$$\begin{aligned}H_a &= H_m + E_0 \times h_{fl} - L_0 \times h_{gl} \\ &= 22.12 + 0.843 \times 6.89 + 0.468 \times (230 \times 0.07) \\ &= 35.46 \text{ m}\end{aligned}$$

h) Pressure desired in the main pipe

$$H_a = H_m + h_y = 35.46 + 0.54 = 36 \text{ m.}$$

i) System flow rate

$$Q = Q_m = 6.12 \text{ m}^3/\text{h}$$

ELEMENTS OF THE CONTROL UNIT

As the water source is hydrant with the pipe system from the open channel, there will be algae, suspended matter and sand in the irrigation water. Therefore, the elements of the control unit are as follows:

Algae (Graver) Filter

Disc Filter

Fertiliser tank

FERTILISER TANK:

$$V = (F \cdot A) / C$$

At the design stage, it is assumed that $F = 3,5 \text{ kg/da}$, $C = 0.5 \text{ kg/l}$.

$$V = 70 \text{ L}$$

ALGAE FILTER: Load losses 0.95 m

DISC FILTER: Load losses 0.18 m

FITTINGS: 0.97 m

PUMP EXIT PRESSURE: $H_h = H_a + H_f = 346 + 0.95 + 0.18 + 0.97 = 38.10 \text{ m.}$

MANOMETER HEIGHT: $H_m = H_h + H_{dh} = 38.10 + 0.5 = 38.60 \text{ m.}$

Hydrant properties: $H_m = 38.60 \text{ m}$, $Q = 6.12 \text{ m}^3/\text{h}$.

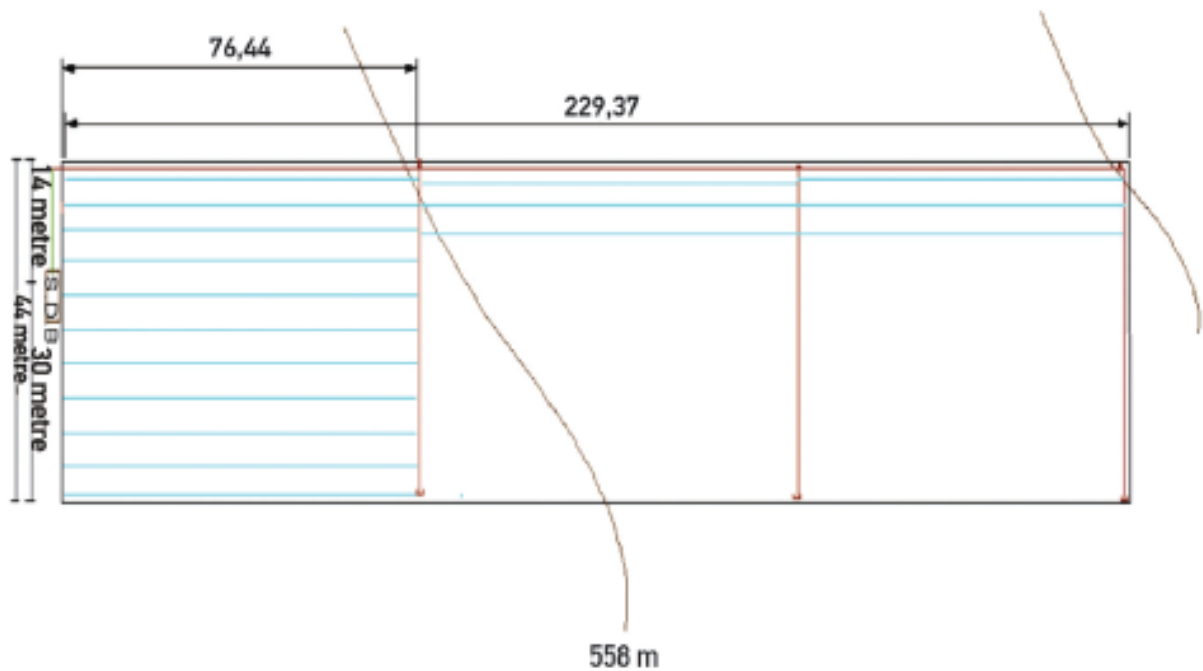

Materials bill of quantity of the project:

No.	TYPE OF MATERIAL	AMOUNT	UNIT
1	(2"X2") 3" SINGLE BACKWASH ALGAE (GRAVER) FILTER UNIT	1	ea
2	100 L FERTILISER TANK	1	ea
3	Ø 75 / 6 ATU PE PIPE	250	m
4	Ø 60 / 6 ATU PE PIPE	250	m
5	3" X 2 ½ " GALVANISED M.F. REDUCTION	1	ea
6	75 X 2 ½ " PE MALE ELBOW	1	ea
7	75 mm COUPLING PE SLEEVE	3	ea
8	50 mm COUPLING PE SLEEVE	3	ea
9	1 ½ " FULL BORE VALVE	3	ea
10	75 X 1 ½ " PE COUPLING MALE TE	3	ea
11	50 X 1 ½ " PE COUPLING MALE ELBOW	3	ea
12	75 mm COUPLING BLIND PLUG	1	ea
13	50 mm COUPLING BLIND PLUG	3	ea
14	16/90/6 IN-LINE B.R. LATERAL	3000	m
15	16 mm 5 ATU YPE PIPE	80	m
16	Ø 75/90 PE ELBOW	2	ea
17	16 mm SAFETY DRIP OUTLET NIPPLE	80	ea
18	16 mm EXPANSION NIPPLE	80	ea
19	16 mm SOFT TYPE DRIP GASKET	80	ea
20	16 mm INSERT BLIND PLUG	80	ea

The Irrigation Schedule (IS) calculated after the project is implemented on the land by the Penman-Monteith method with the CROPWAT software and monitoring form:

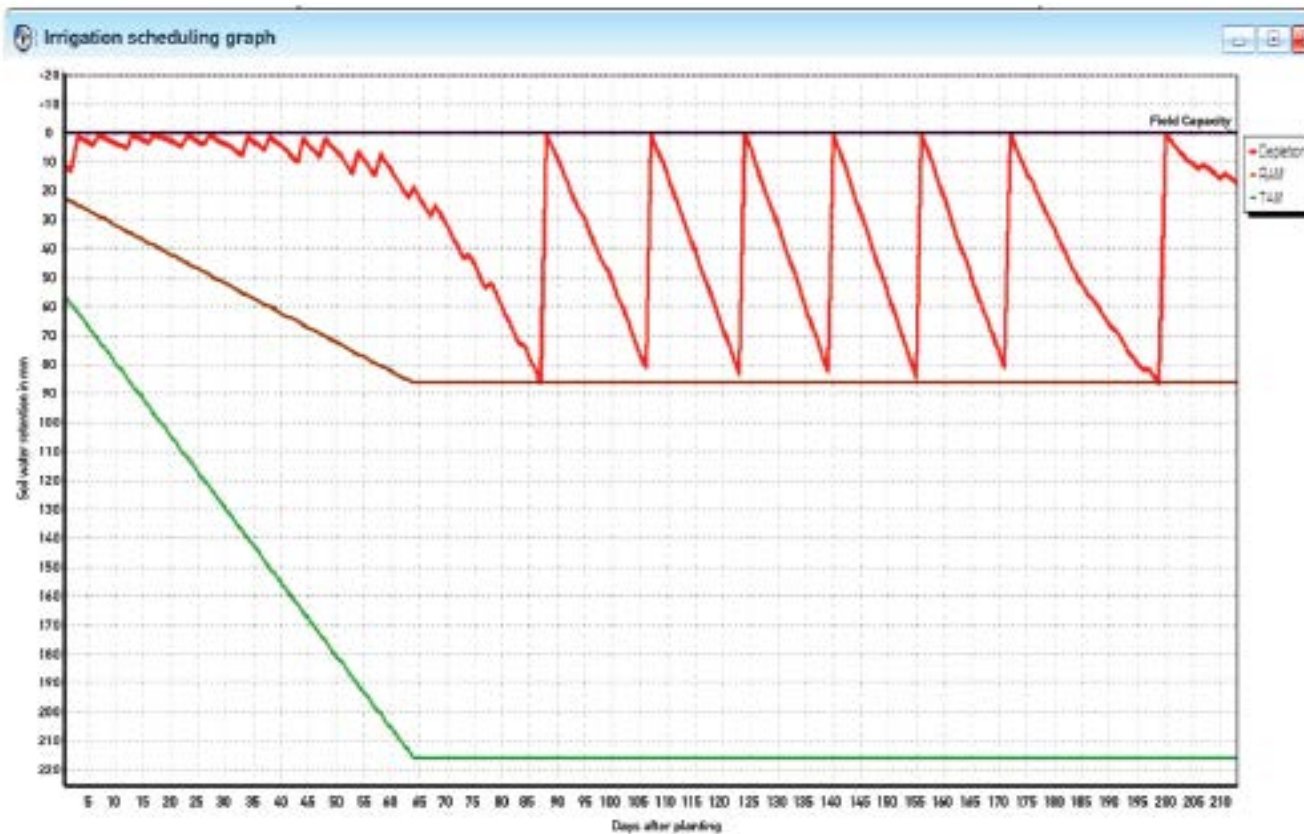

Date	Days	Period	Amount of Net Irr. Water (mm)
27 May	88	Budding	86.5
15 June	107	Budding	86.6
2 July	124	Budding	89.2
18 July	140	Fruit	88.1
3 August	156	Fruit	90.0
19 August	172	Maturing	86.5
16 September	200	Harvest	88.4
		Total	615.4

PROJECT EXAMPLE 3 DRIP IRRIGATION PROJECT

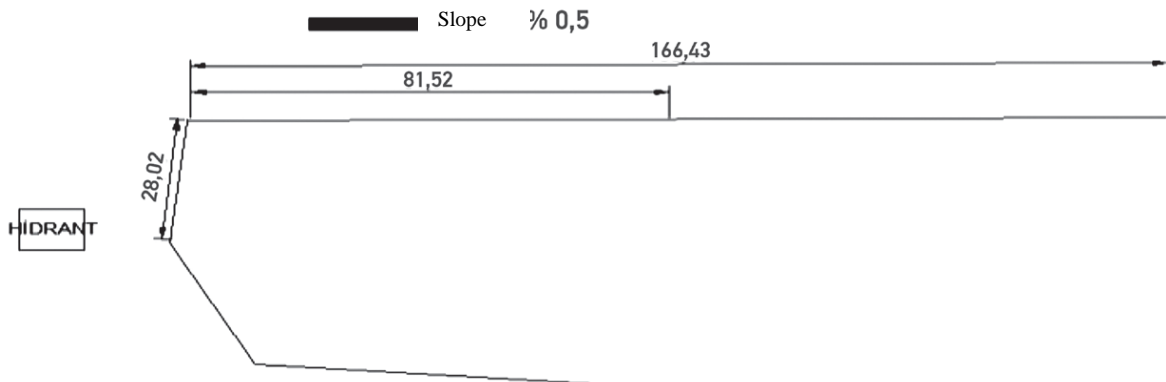

TOMATO (OTURAK) (Şanlıurfa - Centre)

Area	: 5 da
Soil Structure Class	: Clayey loam
Tomato Planting Spacings	: $S_s \times S_a = 0.60 \times 1.40$ m
Maximum Consumptive Water Use of the Plant	: $E.T = 6.7$ mm/ day
Seasonal Total Irrigation Water Need	: 1739 mm/ season
Total Amount of Irrigation Water	: 1217 mm
Hydrant (canalette) Flow Rate	: $Q = 13$ L/s
Irrigation Water Quality Class	: C2 S1
Usable Water Holding Capacity	: $dk = 170$ mm/m
Water Intake Rate	: $I = 13$ mm/h
Effective Root Depth	: 90 cm

Monthly consumptive water use of the plant as calculated by the Penman – Monteith method in the CROPWAT software are as follows:

Month	Avg Temp °C	Humidity %	Wind m/s	Sun hours	Rad MJ/m ² /day	ET _o mm/day
January	5.8	71	0.9	4.1	7.8	0.85
February	7.1	67	1.0	5.0	10.7	1.23
March	11.1	62	1.1	6.2	14.8	2.04
April	16.3	58	1.2	7.7	19.3	3.19
May	22.5	47	1.3	9.6	23.6	4.71
June	28.4	36	1.6	11.4	26.8	6.39
July	32.2	33	1.7	11.7	26.8	7.14
August	31.4	37	1.5	11.4	24.9	6.44
September	26.9	40	1.3	10.1	20.5	4.82
October	20.3	49	0.9	8.2	14.8	2.81
November	12.6	62	0.9	6.0	9.9	1.49
December	7.5	71	0.8	4.2	7.3	0.86
Average	18.5	53	1.2	8.0	17.3	3.50

Monthly consumptive water use of the plant calculated in accordance with the drip irrigation method by the Penman – Monteith method in the CROPWAT software are as follows:

Monthly measured ETo - C:\ProgramDat...	
Station MERKEZ/ŞENOCAK/DOM	
	ETo
	mm/day
January	0.8
February	1.2
March	1.9
April	3.0
May	4.0
June	6.0
July	6.7
August	6.0
September	4.5
October	2.6
November	1.4
December	0.8
Average	3.3

Process Steps:

1- Operation Pressure:

As pressure is provided by a pump, it is assumed $h_o = 1.0$ atm.

2- Optional Dripper Flow Rates:

Optional dripper flow rates at 1.0 atm operation pressure (in accordance with market conditions)

$$q = 1.2 \text{ L/h}$$

$$q = 2.0 \text{ L/h}$$

$$q = 4.0 \text{ L/h}$$

3- Dripper Spacings in Optional Dripper Flow Rates:

For $q = 1.2 \text{ L/h}$; $S_d = 0,9 \times \sqrt{q/I}$

$$S_d = 0,9 \times \sqrt{1.2/13} = 0.27 \text{ m (assumed to be 0.25 m as it cannot be found on the market)}$$

For $q = 2.0 \text{ L/h}$; $S_d = 0,9 \times \sqrt{q/I}$

$$S_d = 0,9 \times \sqrt{2.0/13} = 0.35 \text{ m (assumed to be 0.40 m as it cannot be found on the market)}$$

For $q = 4.0 \text{ L/h}$; $S_d = 0,9 \times \sqrt{q/I}$

$$S_d = 0,9 \times \sqrt{4.0/13} = 0.49 \text{ m (assumed to be 0.50 m as it cannot be found on the market)}$$

4- Ratio of Wetted Area:

$P = k \times (S_d / S_l)$; $k = 1.0$.
For $q = 1.2 \text{ L/h}$; $P = 1.0 (0.30 / 1.40) = 0.21 = \% 21$
For $q = 2.0 \text{ L/h}$; $P = 1.0 (0.40 / 1.40) = 0.29 = \% 29$
For $q = 4.0 \text{ L/h}$; $P = 1.0 (0.50 / 1.40) = 0.36 = \% 36$
P must be ≥ 0.30 . Of these drippers, the 4.0 L/h drippers provide the suitable wetting area.

4- Suitable Dripper Flow Rate:

The $q = 4.0 \text{ L/h}$ dripper flow rate is considered appropriate.
In this project, the dripper with a flow rate of 4.0 L/h at 1.0 atm operation pressure is chosen.

PRELIMINARY PROJECT FACTORS

Dripper flow rate : 4.0 L/h
Dripper spacing (S_d) : 0.50 m
Lateral spacing : 1.40 m
Ratio of wetted area (P) : 0.36

SYSTEM LAYOUT:

Lateral pipelines must be either parallel to contour lines or they must have down slope inclinations. Manifold pipelines must be perpendicular to the laterals, they must have no slope or must be down slope. Main pipelines follow the parcel borders as far as possible.

1) Lateral Pipe Diameter:

- a) Lateral length, $L_l = 82 \text{ m}$
- b) Number of drippers on the lateral
 $n_d = L_l / S_d = 82 / 0.50 = 164$
- c) Lateral Flow Rate
 $Q_l = n_d \times q = 164 \times 4.0 = 656 \text{ L/h}$
- d) Lateral Slope
 $S_l = \% 0.5$ (down slope) and $E_o = 0.705$, $L_o = 0.358$
- e) Operation Pressure
 $h_o = 1.0 \text{ atm} = 10 \text{ m}$
- f) It is decided that the lateral pipeline is made of PE drip irrigation pipes with 4 atm operation pressure
- g) Lateral Pipe Diameter;
20 mm diameter lateral pipe at 1.0 operation pressure, with 4.05 m load loss and 0.81 m/s flow rate is chosen in accordance with Williams Hazen.

14) Lateral Entrance Pressure

$H_l = h_o + h_{fl} \times E_o - h_{gl} \times L_o$
 $H_l = 10 + 4.05 \times 0.705 - (82 \times 0.005) \times 0.358$
 $H_l = 12.85 \text{ m}$

15) Manifold Pipe Diameter

- a) Manifold Length
 $L_m = 30 \text{ m}$
- b) Number of laterals on the Manifold

$$n_l = 21$$

c) Manifold Flow Rate

$$Q_m = n_l \cdot q = 21 \times 656 = 13\,776 \text{ L/h}$$

d) Manifold Slope

$$S_m = \% 0 \text{ (no slope)} \quad E_o = 0.738, \quad L_o = 0.370$$

e) Lateral entrance pressure

$$H_l = 12.85 \text{ m}$$

f) Manifold pipelines will be made of hard PE pipes with 6 atm operation pressure.

g) Manifold Pipe Diameter

Under conditions of 1.34 m load loss and 1.59 m/s average flow rate, pipe diameters are chosen as follows, in accordance with William Hazen

$$\text{Ø } 63/6 - 30 \text{ m}$$

Manifold pipelines will be made of PE pipes with 6 atm operation pressure.

i) Manifold entrance pressure

$$H_m = H_l + h_{fl} \times E_o - h_{gl} \times L_o$$

$$H_m = 12.85 + 1.34 \times 0.738 - (30 \times 0.0) \times 0.370$$

$$H_m = 13.84 \text{ m}$$

16) Main Pipe Diameter

a) Main Pipe Length

$$L_a = 88 \text{ m}$$

b) Number of manifolds on the main pipe

$$n_a = 1$$

c) Main Pipe Flow Rate

$$Q_m = Q_a = 13\,776 \text{ L/h}$$

$$H_m = 13.84 \text{ m}$$

d) Main pipelines will be made of PE pipes with 6 atm operation pressure.

e) Main Pipe Diameter

Under conditions of 3.85 m load loss and 1.59 m/s average flow rate, pipe diameters are chosen as follows, in accordance with William Hazen.

$$\text{Ø } 63/6 - 88 \text{ m}$$

h) Main pipe entrance pressure

$$H_a = H_l + h_{fl} \times E_o - h_{gl} \times L_o$$

$$H_a = 13.84 + 3.85 \times 0.705 - (88 \times 0.0) \times 0.370$$

$$H_a = 16.55 \text{ m}$$

i) Pressure desired in the main pipe

$$H_a = H_m + h_y = 16.55 + 0.44 = 17 \text{ m.}$$

i) System flow rate

$$Q = Q_m = 13.78 \text{ m}^3/\text{h} = 3.82 \text{ L/s}$$

ELEMENTS OF THE CONTROL UNIT

As the water source is hydrant with the pipe system from the open channel, there will be algae, suspended matter and sand in the irrigation water. Therefore, the elements of the control unit are as follows:

Algae (Graver) Filter
Disc Filter
Fertiliser tank

FERTILISER TANK:

$$V = (F \cdot A) / C$$

At the design stage, it is assumed that $F = 3,5 \text{ kg/da}$, $C = 0,5 \text{ kg/l}$.

$$V = 35 \text{ L}$$

ALGAE FILTER: Load losses 0.95 m

DISC FILTER: Load losses 0.18 m

FITTINGS: 0.97 m

PUMP EXIT PRESSURE: $H_h = H_a + H_f = 17 + 0.95 + 0.18 + 0.97 = 19.10 \text{ m}$.

MANOMETER HEIGHT: $H_m = H_h + H_{dh} = 19.1 + 1.0 = 20.10 \text{ m}$.

Hydrant properties: $H_m = 20.10 \text{ m}$, $Q = 3.82 \text{ L/s}$.

Implementation of the project on the land:

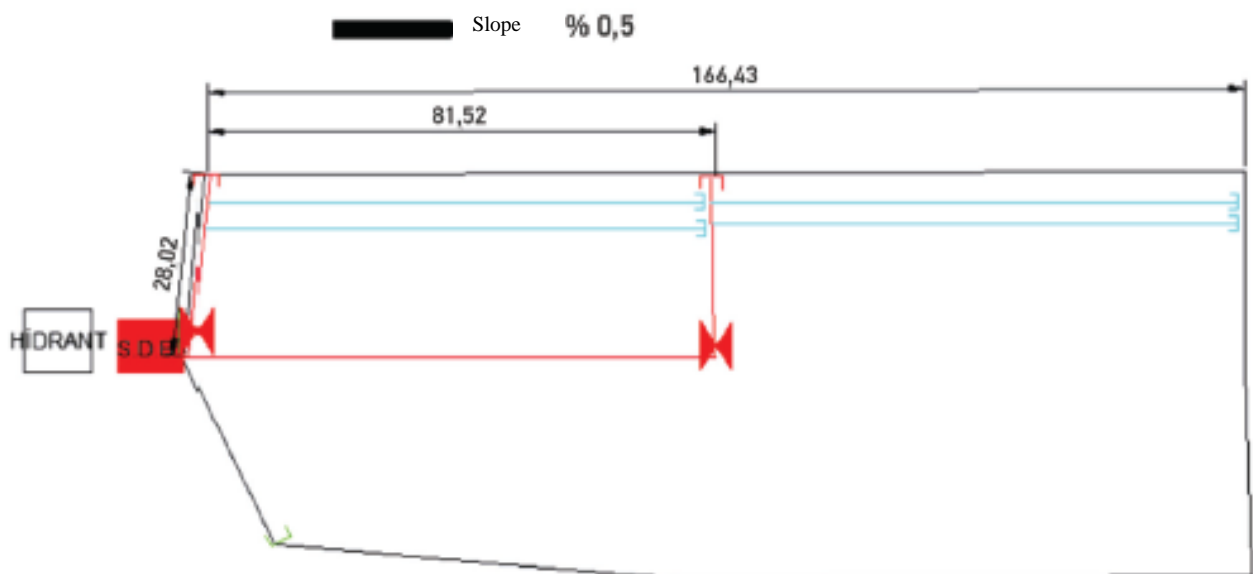

Materials bill of quantity of the project:

No.	TYPE OF MATERIAL	AMOUNT	UNIT
1	3" SINGLE BACKWASH ALGAE (GRAVER) FILTER UNIT	1	ea
2	50 L FERTILISER UNIT	1	ea
3	Ø 63 / 6 ATU PE CLIPPED PIPE	144	m
4	Ø 63 / 6 ATU PE CLIPPED PIPE GASKET	24	ea
5	20/50/4 IN-LINE ROUND DRIP LATERAL	3600	m
6	Ø63 PE CLIPPED FEMALE MOTOPOMP (MALE)	2	ea
7	Ø63 PE CLIPPED VALVE	2	ea
8	63 X 63 PE CLIPPED ELBOW	2	ea
9	Ø63 PE CLIPPED BLIND PLUG	2	ea
10	Ø63 PE CLIPPED PIPE CROSS	2	ea
11	20 mm EXPANSION NIPPLE	100	ea
12	20 mm SOFT TYPE DRIP GASKET	100	ea
13	20 mm INSERT BLIND PLUG	100	ea

The Irrigation Schedule (IS) calculated after the project is implemented on the land by the Penman-Monteith method with the CROPWAT software and monitoring form:

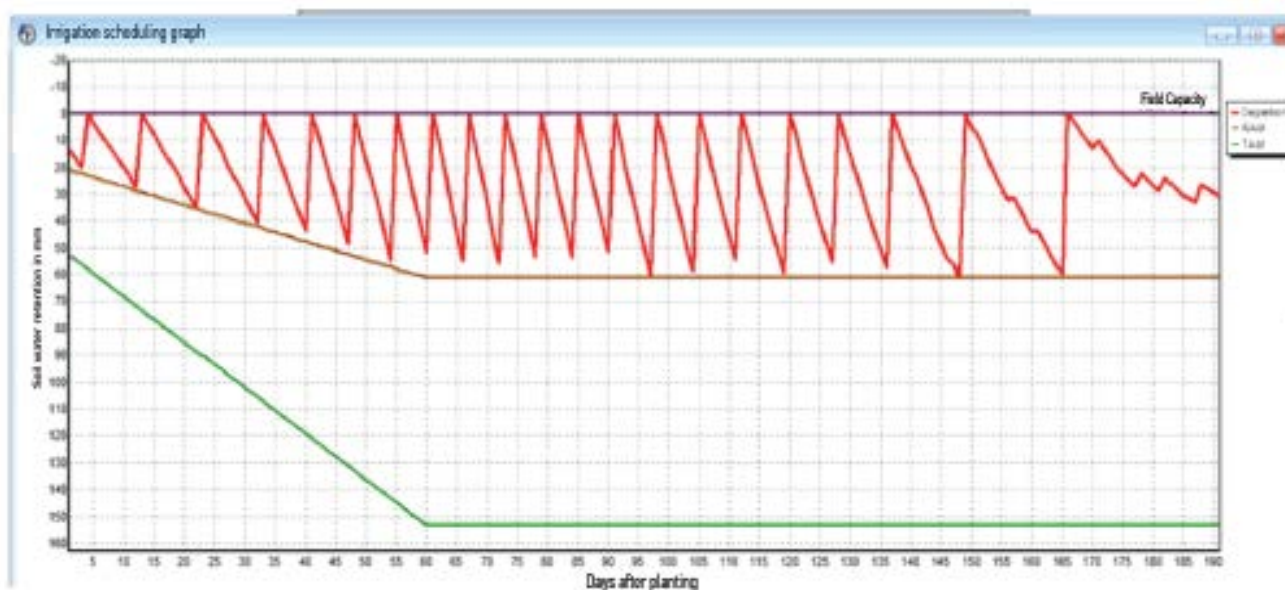

Date	Days	Period	Amount of Net Irr. Water (mm)
13 May	4	Initial	23.3
22 May	13	Initial	31.5
1 June	23	Initial	39.9
11 June	33	Development	47.1
19 June	41	Development	50.3
26 June	48	Development	56.7
3 July	55	Development	64.9
9 July	61	Fruit	62.2
15 July	67	Fruit	66.0
21 July	73	Fruit	66.6
27 July	79	Fruit	64.4
2 August	85	Fruit	63.6
8 August	91	Fruit	61.6
15 August	98	Fruit	70.1
22 August	105	Fruit	67.7
29 August	112	Fruit	63.4
6 September	120	Fruit	67.7
14 September	128	Fruit	62.8
23 September	137	Fruit	62.1
5 October	149	Fruit	66.5
22 October	166	Fruit	63.0
		Total	1221.5

BIBLIOGRAPHY

- GÜNGÖR, Y.; ERÖZEL, Z.; YILDIRIM, O., 2004 Sulama (Irrigation). Ankara University Faculty of Agriculture Publications 1540, Ankara
- GÜNGÖR, Y.; ERÖZEL, Z.; YILDIRIM, O., 1996 Sulama (Irrigation). Ankara University Faculty of Agriculture Publications 1443, Ankara
- OPANOĞLU, N.; SÜLLÜ, A.; EZBER, Y.; ÖZENÇ, L.; AKILLI, E.; SABAH, M., 2010 Sulama Projelerinin Yapımı ve Değerlendirme Kriterleri (Design of Irrigation Projects and the Evaluation Criteria). T.R. Ministry of Agriculture and Rural Works Söke Agricultural Production Establishment Extension and In-Service Training Centre Directorate
- ÇETİN, Ö; 2012. Sulama ve Fertigasyon Eğitim Notları (Irrigation and Fertigation Training Notes). GAP BKİ Administration GAP TEYAP Irrigation Group Training Notes
- YENİKALE, A; Havalandırılmış Sulama Suyunun Soğan Bitkisi Tuz Toleransına Olan Etkileri (Effects of Ventilated Irrigation Water on the Salt Tolerance of the Onion Plant), 2004, Ankara University Science Institute T.Y.S. Department Master's Thesis,
- YENİKALE A; GAP TEYAP Sulama Demonstrasyon Projeleri ve SZP (GAP TEYAP Irrigation Demonstration Projects and SZP), 2012, GAP BKİ Administration GAP TEYAP Irrigation Group Training Notes, DSİ General Directorate Publications, www.dsi.gov.tr,



“T.R. (TURKISH REPUBLIC) MINISTRY OF
DEVELOPMENT SOUTH-EASTERN ANATOLIA
PROJECT REGIONAL DEVELOPMENT
ADMINISTRATION”

www.gap.gov.tr - www.gapep.gov.tr

